

ST RANGE SUPPLEMENTARY ACCESSORY PARTS LIST

INDEX

ENGINE	DESCRIPTION	KIT NO.	PAGE
ADAPTOR			
ST1	Wisconsin 5-3/4" Pilot	998-00015	4
ST1	Wisconsin 7" Pilot	998-00016	4
ST2/3	Wisconsin 7" Pilot	998-00017	6
ST2/3	Wisconsin 7-7/8" Pilot	998-00018	6
ST2/3	SAE #5	570-15230	12
CLUTCH			
ST1	Twin Disc C-106SP5	998-00019	8
ST1	Clutch Drive C-106	998-00002	8
ST2/3	Twin Disc C-106SP5	998-00020	12
ST2/3	Clutch Drive C-106	998-00003	12
ST1	Clutch Drive Automotive SAE J618C	998-00184	16
ST2/3	Clutch Drive Automotive SAE J618C	998-00039	18
CRANKSHAFT EXTENSIONS (FLYWHEEL END)			
ST1/2/3	Shaft Extension - Std.	998-00059	20
ST1/2/3	Shaft Extension - Long	998-00060	20
ST1/2/3	Shaft Extension - Long - Semi-Finished	998-00055	20
ELECTRIC STARTING			
ST1	12V Electric Starting w/Push Button & Ammeter	998-00007	22
ST1	Alternator Fitting Kit	657-17724	22
ST2/3	12V Electric Starting w/Push Button & Ammeter	998-00125	26
ST2/3	Alternator Fitting Kit	657-21930	26
FUEL CONTROL - AUTOMATIC			
ST1/2/3	Energize to Run	998-00095	30
ST1/2/3	Energize to Run & Two Speed Control	998-00071	34
ST1/2/3	Two Speed Control	998-00113	38
ST1/2/3	Energize to Stop	998-00101	40
FUEL FITTINGS			
ST1/2	Fuel Inlet and Return Connector to 1/8" NPT	998-00123	42

Continued on next page

ST RANGE SUPPLEMENTARY ACCESSORY PARTS LIST

INDEX

ENGINE	DESCRIPTION	KIT NO.	PAGE
GUARDS			
ST2/3	Wisconsin Adaptor Guard	998-00181	6
ST2/3	SAE #5 Guard	202-18360	12
ST1	Alternator Drive Guard	988-00150	44
ST2/3	Alternator Drive Guard	998-00200	46
INSTRUMENTS			
ST1/2/3	Tachometer - Hour Meter	998-00013	48
ST1/2/3	Lube Oil Pressure Gallery	998-00001	50
ST1/2/3	Lube Oil Pressure Gauge	998-00005	50
TEMPERATURE SWITCH			
ST1/2/3	High Air Temperature Switch N/O	998-00142	52
ST1/2/3	High Air Temperature Switch N/C	998-00134	52
VARIABLE SPEED CONTROL			
ST1/2/3	Variable Speed Control Conversion	998-00014	54
ST1/2/3	Variable Speed Control Less Governor Weights	998-00189	54

This page is intentionally left blank

ST1 WISCONSIN TYPE ADAPTOR

WISCONSIN ADAPTOR KIT WITH GUARD -

6-1/2" B.C.D. 5-3/4" PILOT DIA. 998-00015

	DESCRIPTION	PART NO.	QTY
1.	ADAPTOR - 5-3/4" Pilot Dia.	000-00439	1
2.	SPRING WASHER - 5/16"	027-00413	10
3.	SETSCREW - 5/16" UNF X 1" Lg.	270-00061	10
4.	SPRING WASHER - 3/8"	027-00393	2
5.	SETSCREW - 3/8" UNF X 1" Lg.	270-00073	2
6.	GUARD	000-00989	2
7.	SETSCREW - 1/4" UNF X 1/2" Lg.	270-00054	4
8.	SPRING WASHER - 1/4"	027-00451	4
9.	FLAT WASHER - 1/4"	064-06618/G	4
10.	CLAMP	366-06524	4

WISCONSIN ADAPTOR KIT - 7-3/4" B.C.D., 7" PILOT DIA. 998-00016

	DESCRIPTION	PART NO.	QTY
1.	ADAPTOR - 7" Pilot Dia.	000-00440	1
2.	SPRING WASHER - 5/16"	027-00413	10
3.	SETSCREW - 5/16" UNF X 1" Lg.	270-00061	10
4.	SPRING WASHER - 3/8"	027-00393	2
5.	SETSCREW - 3/8" UNF X 1" Lg.	270-00073	2
6.	GUARD	000-00989	2
7.	SETSCREW - 1/4" UNF X 1/2" Lg.	270-00054	4
8.	SPRING WASHER - 1/4"	027-00451	4
9.	FLAT WASHER - 1/4"	064-06618/G	4
10.	CLAMP	366-06524	4

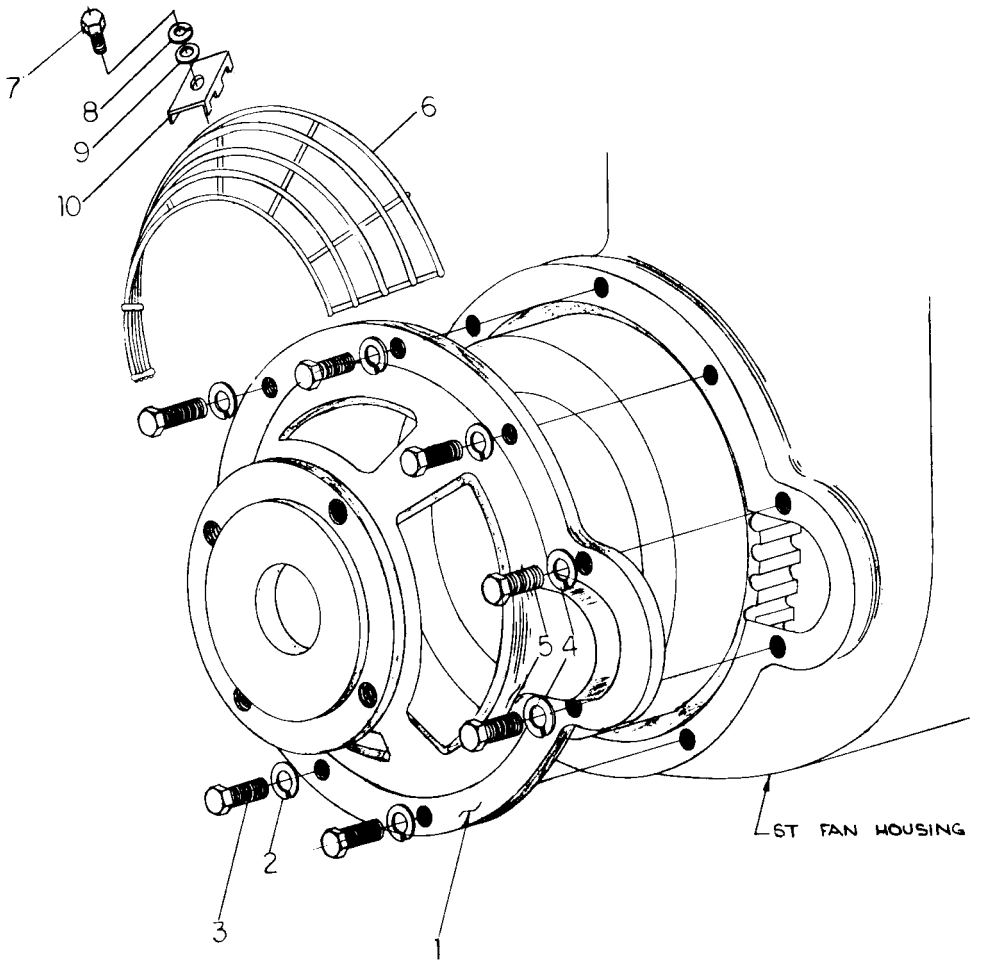

1-2877/1

WISCONSIN TYPE ADAPTOR—ST1

ST2/3 WISCONSIN TYPE ADAPTOR

WISCONSIN ADAPTOR KIT - WITH GUARD -

7-3/4" B.C.D., 7" - PILOT DIA. 998-00017

	DESCRIPTION	PART NO.	QTY
1.	ADAPTOR - 7" Pilot	000-00389	1
2.	SPRING WASHER - 3/8"	027-00393	8
3.	SETSCREW - 3/8" UNC X 1" Lg	270-00288	8
	GUARD ASSEMBLY	998-00181	
4.	GUARD	000-00988	2
5.	CLAMP - Guard	366-06524	4
6.	PLAIN WASHER - 1/4"	064-06618/G	4
7.	SPRING WASHER - 1/4"	027-00451	4
8.	SETSCREW - 1/4" UNF X 1/2" Lg.	270-00054	4

WISCONSIN ADAPTOR KIT - WITH GUARD -

8-5/8" B.C.D., 7-7/8" - PILOT DIA. 998-00018

	DESCRIPTION	PART NO.	QTY
1.	ADAPTOR	000-00390	1
2.	SPRING WASHER - 3/8"	027-00393	8
3.	SETSCREW - 3/8" UNC X 1" Lg.	270-00288	8
	GUARD ASSEMBLY	998-00181	
4.	GUARD	000-00988	2
5.	CLAMP - Guard	366-06524	4
6.	PLAIN WASHER - 1/4"	064-06618/G	4
7.	SPRING WASHER - 1/4"	027-00451	4
8.	SETSCREW - 1/4" UNF X 1/2" Lg.	270-00054	4

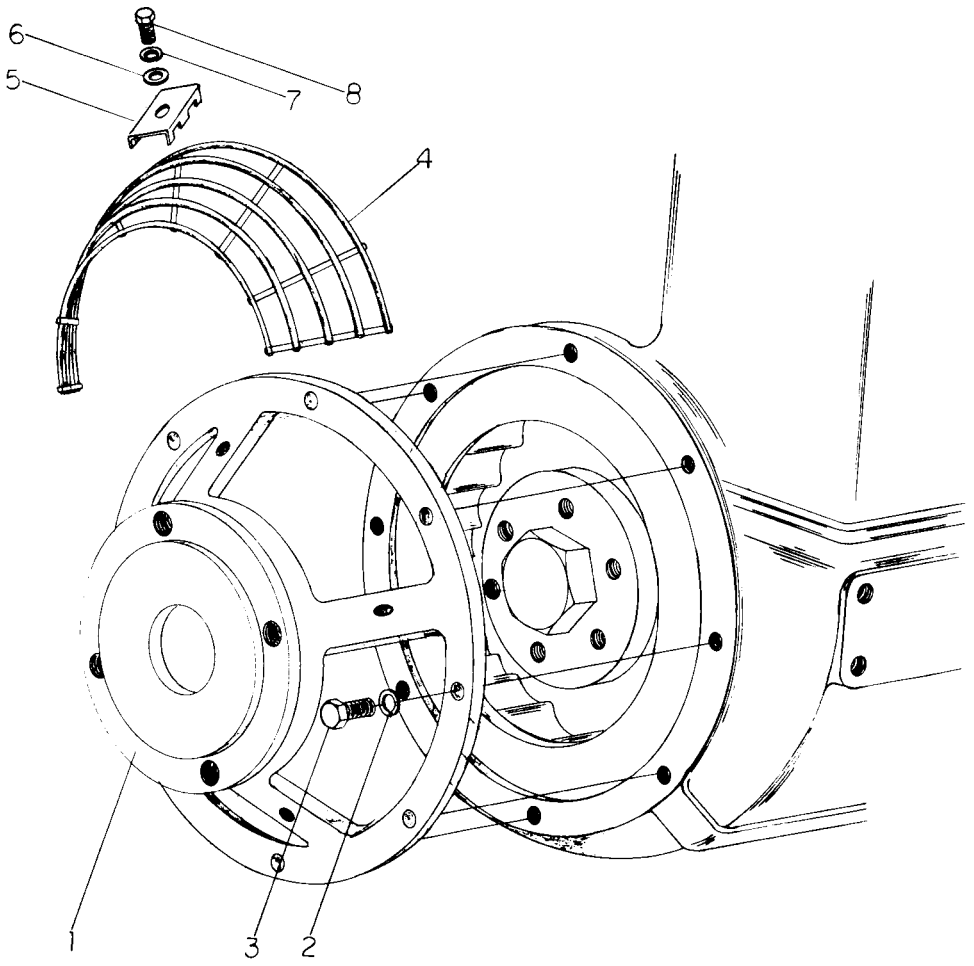

1-2879/2

WISCONSIN TYPE ADAPTOR—ST2/3

ST1 TWIN DISC CLUTCH - (C-106SP5) W/ADAPTOR & DRIVE MEMBER

TWIN DISC CLUTCH C-106SP5 ASSEMBLY 998-00019

DESCRIPTION	PART NO.	QTY
CLUTCH DRIVE MEMBER (C106, J620C) KIT	998-00002	
1. CLUTCH DRIVE MEMBER - 6"	366-05721	1
2. STUD - 7/16" UNF X 2-1/2"	270-00402	3
3. SPRING WASHER - 7/16"	027-00984	3
4. NUT - 7/16" UNF	270-00311	3
5. PILOT BEARING	W/CLUTCH	1
6. CLUTCH DRIVE RING	W/CLUTCH	1
7. SPRING WASHER - 5/16"	027-00413	6
8. BOLT - 5/16" UNC X 1-1/4" Lg.	270-00620	6
SAE #5 ADAPTOR ASSEMBLY	570-13750	
9. SAE #5 ADAPTOR	201-14930	1
10. SPRING WASHER - 3/8"	027-00393	2
11. BOLT - 3/8" UNF X 1" Lg.	270-00073	2
12. SPRING WASHER 5/16"	027-00413	10
13. BOLT - 5/16" UNF X 1" Lg.	270-00061	10
14. ADAPTOR GUARD	201-14070	3
15. SPRING WASHER - 1/4"	027-00451	6
16. BOLT - 1/4" UNF X 5/8" Lg.	270-00276	6
17. CLUTCH - TWIN DISC	000-00060	1
18. SPRING WASHER - 3/8"	027-00393	8
19. BOLT - 3/8" UNF X 1" Lg.	270-00073	8
20. HAND LEVER	W/CLUTCH	1

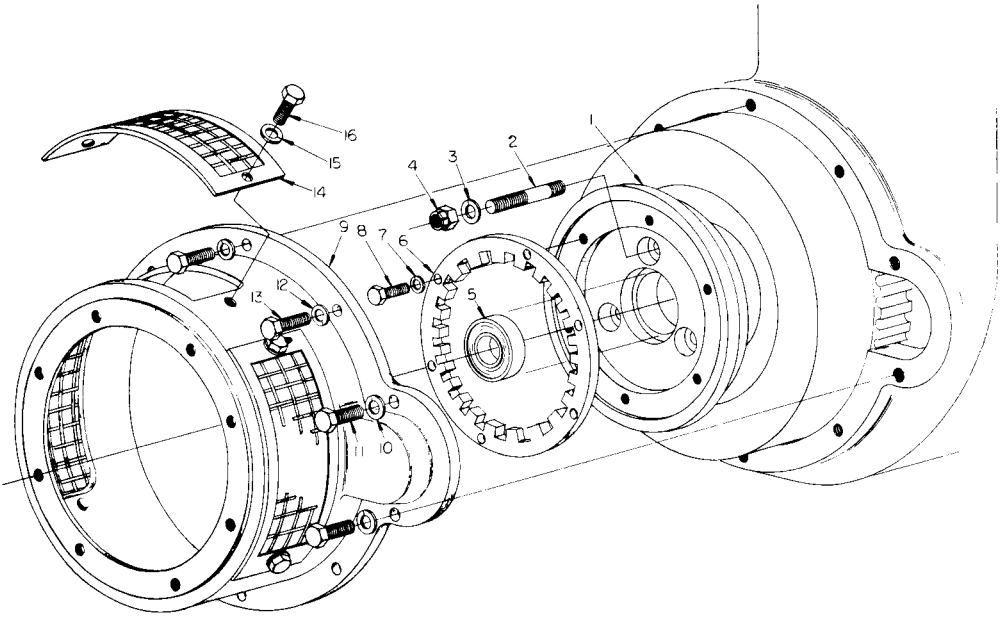

1-2478/3

TWIN DISC CLUTCH—(C106SP5) W/ADAPTOR & DRIVE MEMBER—ST1

ST1 TWIN DISC CLUTCH - (C-106SP5) W/ADAPTOR & DRIVE MEMBER

TWIN DISC CLUTCH C-106SP5 ASSEMBLY 998-00019

DESCRIPTION	PART NO.	QTY
CLUTCH DRIVE MEMBER (C106, J620C) KIT	998-00002	
1. CLUTCH DRIVE MEMBER - 6"	366-05721	1
2. STUD - 7/16" UNF X 2-1/2"	270-00402	3
3. SPRING WASHER - 7/16"	027-00984	3
4. NUT - 7/16" UNF	270-00311	3
5. PILOT BEARING	W/CLUTCH	1
6. CLUTCH DRIVE RING	W/CLUTCH	1
7. SPRING WASHER - 5/16"	027-00413	6
8. BOLT - 5/16" UNC X 1-1/4" Lg.	270-00620	6
SAE #5 ADAPTOR ASSEMBLY	570-13750	
9. SAE #5 ADAPTOR	201-14930	1
10. SPRING WASHER - 3/8"	027-00393	2
11. BOLT - 3/8" UNF X 1" Lg.	270-00073	2
12. SPRING WASHER 5/16"	027-00413	10
13. BOLT - 5/16" UNF X 1" Lg.	270-00061	10
14. ADAPTOR GUARD	201-14070	3
15. SPRING WASHER - 1/4"	027-00451	6
16. BOLT - 1/4" UNF X 5/8" Lg.	270-00276	6
17. CLUTCH - TWIN DISC	000-00060	1
18. SPRING WASHER - 3/8"	027-00393	8
19. BOLT - 3/8" UNF X 1" Lg.	270-00073	8
20. HAND LEVER	W/CLUTCH	1

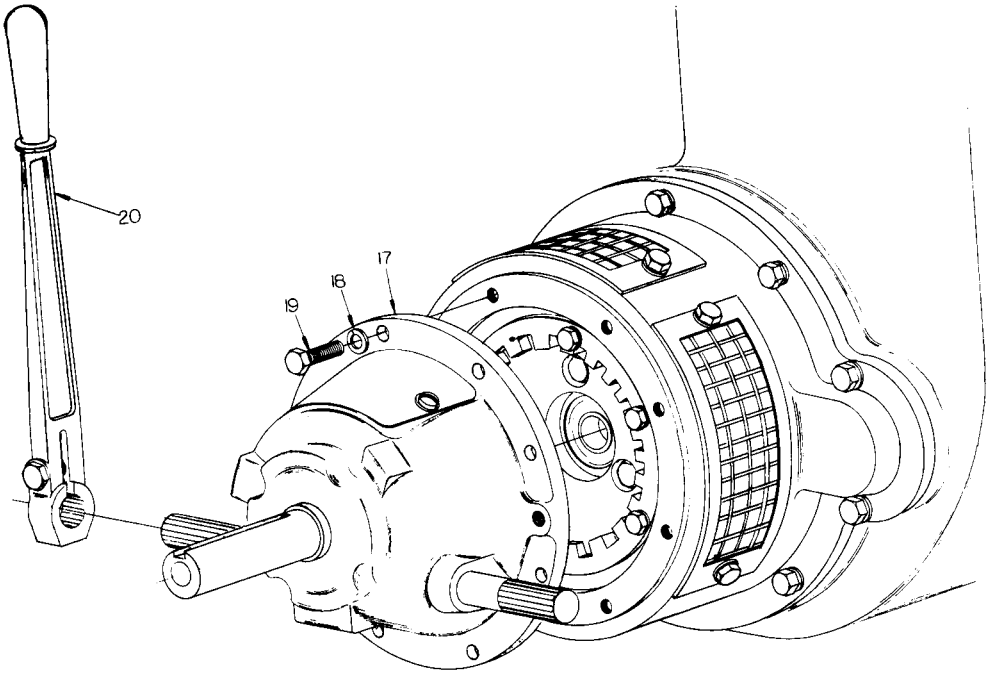

1-2478/4

TWIN DISC CLUTCH—(C106SP5) W/ADAPTOR & DRIVE MEMBER—ST1

ST2/3 TWIN DISC CLUTCH - (C-106SP5) W/ADAPTOR & DRIVE MEMBER

TWIN DISC CLUTCH C-106SP5 ASSEMBLY 998-00020

DESCRIPTION	PART NO.	QTY
CLUTCH DRIVE MEMBER (C106) KIT	998-00003	
1. CLUTCH DRIVE MEMBER - 6"	366-05720	1
2. STUD - 7/16" UNF X 2-1/4" Lg.	270-00471	6
3. SPRING WASHER - 7/16"	027-00984	6
4. NUT - 7/16" UNF	270-00311	6
5. PILOT BEARING	W/CLUTCH	1
6. CLUTCH DRIVE RING	W/CLUTCH	1
7. SPRING WASHER - 5/16"	027-00413	6
8. BOLT - 5/16" UNC X 1-1/4" Lg.	270-00620	6
SAE #5 ADAPTOR ASSEMBLY	570-15230	
9. SAE #5 ADAPTOR	201-14930	1
10. STUD - 3/8" UNF/UNC X 3" Lg.	270-00323	8
11. SPRING WASHER - 3/8"	027-00393	8
12. NUT - 3/8" UNF	270-00004	8
13. *ADAPTOR GUARD ASSEMBLY	202-18360	1
17. CLUTCH - TWIN DISC	000-00060	1
18. SPRING WASHER - 3/8"	027-00393	8
19. BOLT - 3/8" UNC X 1" Lg.	270-00288	8
20. HAND LEVER	W/CLUTCH	1

*Includes Items No. 13, 14, 15 & 16.

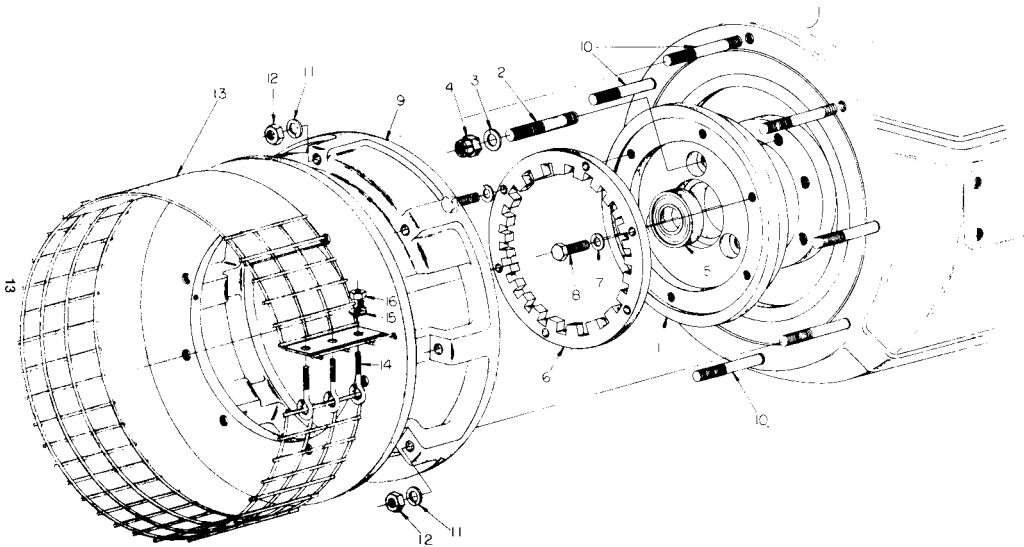

1-2479/5

TWIN DISC CLUTCH—(C106SP5) W/ADAPTOR & DRIVE MEMBER—ST2/3

ST2/3 TWIN DISC CLUTCH - (C-106SP5) W/ADAPTOR & DRIVE MEMBER

TWIN DISC CLUTCH C-106SP5 ASSEMBLY 998-00020

DESCRIPTION	PART NO.	QTY
CLUTCH DRIVE MEMBER (C106) KIT	998-00003	
1. CLUTCH DRIVE MEMBER - 6"	366-05720	1
2. STUD - 7/16" UNF X 2-1/4" Lg.	270-00471	6
3. SPRING WASHER - 7/16"	027-00984	6
4. NUT - 7/16" UNF	270-00311	6
5. PILOT BEARING	W/CLUTCH	1
6. CLUTCH DRIVE RING	W/CLUTCH	1
7. SPRING WASHER - 5/16"	027-00413	6
8. BOLT - 5/16" UNC X 1-1/4" Lg.	270-00620	6
SAE #5 ADAPTOR ASSEMBLY	570-15230	
9. SAE #5 ADAPTOR	201-14930	1
10. STUD - 3/8" UNF/UNC X 3" Lg.	270-00323	8
11. SPRING WASHER - 3/8"	027-00393	8
12. NUT - 3/8" UNF	270-00004	8
13. *ADAPTOR GUARD ASSEMBLY	202-18360	1
17. CLUTCH - TWIN DISC	000-00060	1
18. SPRING WASHER - 3/8"	027-00393	8
19. BOLT - 3/8" UNC X 1" Lg.	270-00288	8
20. HAND LEVER	W/CLUTCH	1

*Includes Items No. 13, 14, 15 & 16.

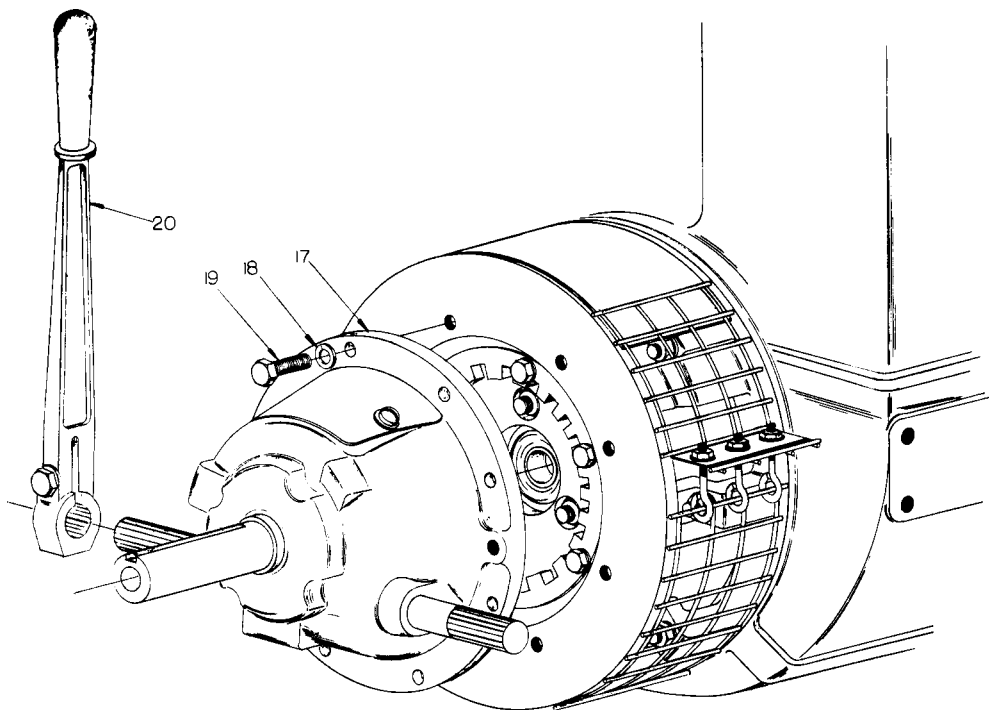

1-2479/5

TWIN DISC CLUTCH—(C106SP5) W/ADAPTOR & DRIVE MEMBER—ST2/3

ST1 CLUTCH DRIVE MEMBER, AUTOMOTIVE - SAE J618C FOR 9 INCH W/SAE5 ADAPTORS

CLUTCH DRIVE MEMBER, AUTOMOTIVE - SAE J618C
FOR 9" CLUTCH W/SAE5 ADAPTOR KIT 998-00184

DESCRIPTION	PART NO.	QTY
1. CLUTCH DRIVE MEMBER - 9"	000-00358	1
2. STUD - 7/16" UNF X 2-3/4"	270-00710	3
3. SPRING WASHER - 7/16"	027-00985	3
4. NUT (Self Locking) - 7/16" UNF	270-00311	3
5. ADAPTOR - SAE5	657-22571	1
- ADAPTOR - SAE5 TO 5	000-00876	1
6. STUD - 3/8" UNF X 2-3/4"	270-00092	8
7. LOCK WASHER - 3/8"	027-00393	8
8. NUT - 3/8" UNF	270-00004	8
9. GUARD	602-38640	1
10. CLAMP (GUARD)	000-00743	2
11. SETSCREW - 1/4" UNC X 1-1/2"	101-00624	2
12. NUT - 1/4" UNC	101-00601	2
13. SPRING WASHER - 1/4"	027-00451	2

*IMPORTANT NOTE:- EQUIPMENT ON THIS KIT MUST BE USED **ONLY**
WITH NARROW FLYWHEEL.

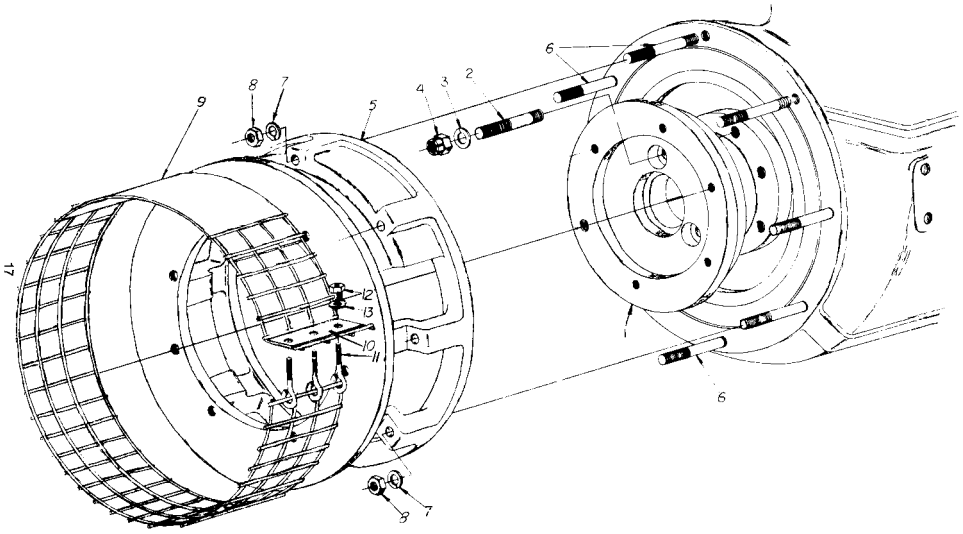

1-2479/19

CLUTCH DRIVE MEMBER, AUTOMOTIVE—SAE J618C FOR 9 INCH CLUTCH W/SAE5 ADAPTORS—ST1

ST2/3 CLUTCH DRIVE MEMBER 9 INCH (J618C)

9" CLUTCH DRIVE MEMBER (J618C) KIT 998-00039

	DESCRIPTION	PART NO.	QTY
1.	CLUTCH DRIVE MEMBER - 9"	000-00358	1
2.	STUD - 7/16" UNF	270-00710	6
3.	SPRING WASHER - 7/16"	027-00985	6
4.	NUT - 7/16" UNF	270-00311	6

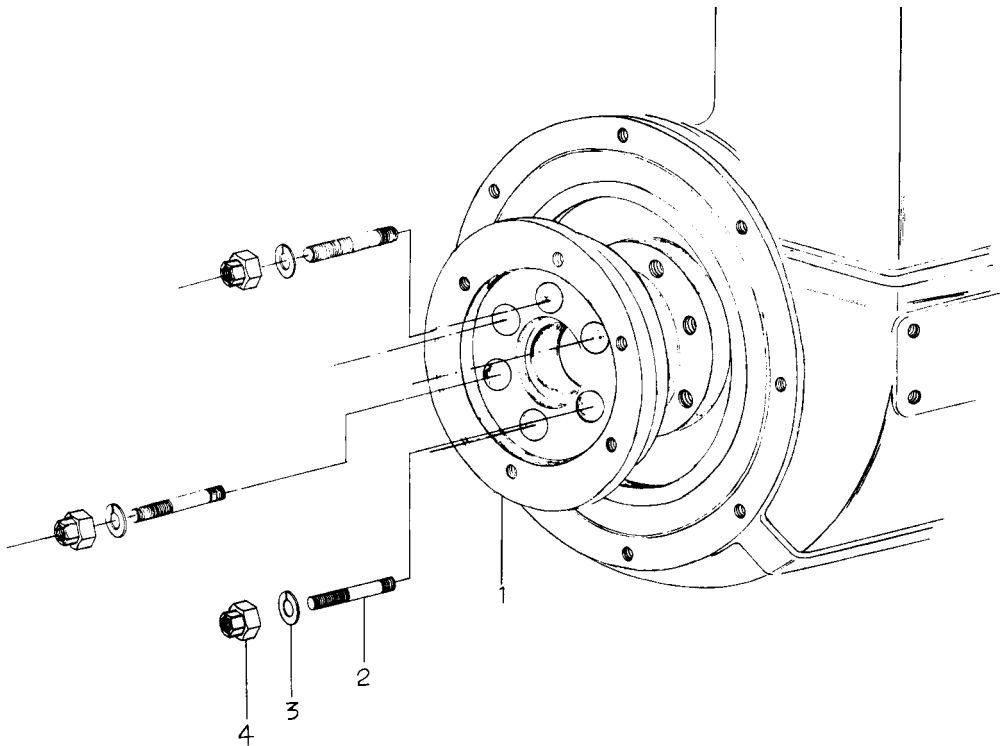

1-292017

CLUTCH DRIVE MEMBER 9 INCH (J618C)—ST2/3

ST2/3 CRANKSHAFT EXTENSIONS

CRANKSHAFT EXTENSION ASSEMBLY - STANDARD 998-00059

	DESCRIPTION	PART NO.	QTY
1.	SHAFT EXTENSION - Standard	000-00306	1
4.	STUD - 7/16" UNF X 2-1/4" Lg.	270-00471	6
5.	SPRING WASHER - 7/16"	027-00984	6
6.	NUT - 7/16" UNF	270-00311	6

CRANKSHAFT EXTENSION ASSEMBLY - LONG 998-00060

	DESCRIPTION	PART NO.	QTY
2.	SHAFT EXTENSION - Long	000-00307	1
4.	STUD - 7/16" UNF X 2-1/4" Lg.	270-00471	6
5.	SPRING WASHER - 7/16"	027-00984	6
6.	NUT - 7/16" UNF	270-00311	6

SHAFT EXTENSION ASSEMBLY - LONG, SEMI-FINISHED 998-00055

	DESCRIPTION	PART NO.	QTY
3.	SHAFT EXTENSION - Long, Rough	000-00623	1
4.	STUD - 7/16" UNF X 2-1/4" Lg.	270-00471	6
5.	SPRING WASHER - 7/16"	027-00984	6
6.	NUT - 7/16" UNF	270-00311	6

SPECIAL SHAFTS AVAILABLE UPON REQUEST.

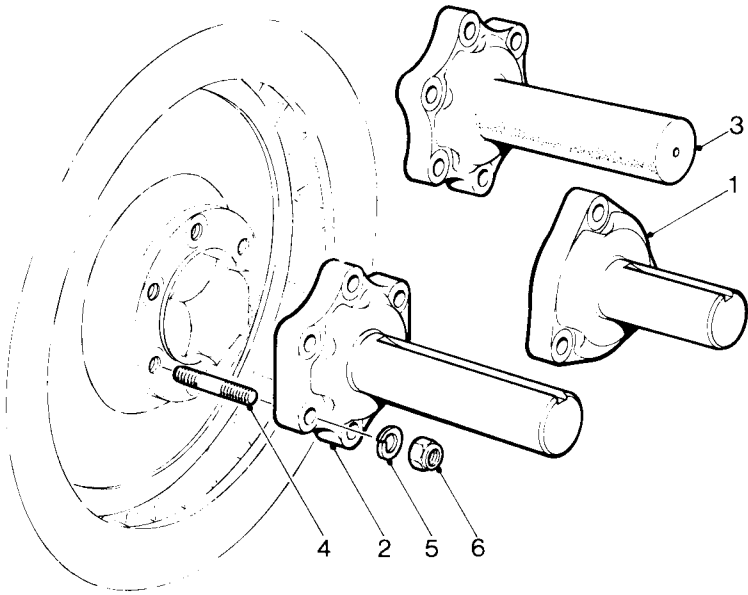

1-1.02277/12

CRANKSHAFT EXTENSION—STANDARD—ST2/3

ST1 ELECTRIC STARTING - 12 VOLT - MOTOROLA ALTERNATOR & DELCO STARTER

12 VOLT ELECTRICAL STARTING KIT 998-00007

DESCRIPTION	PART NO.	QTY
1. ALTERNATOR - With Fan	000-00845	1
2. PULLEY - Alternator	000-00624	1
ALTERNATOR FITTING KIT	657-17724	
3. BRACKET - Alternator	366-03662	1
4. STUD - 5/16" UNF X 1-1/8"	270-00098	2
5. NUT - 5/16" UNF	270-00003	2
6. SPRING WASHER - 5/16"	027-00413	6
7. DISTANCE PIECE	366-03663	2
8. BOLT - 5/16" UNF X 3" Lg.	270-00106	2
9. PLAIN WASHER - 5/16"	027-00082	1
10. ADJUSTING LINK	201-15020	1
11. DISTANCE PIECE	024-05394	1
12. BOLT - 3/8" UNF X 3" Lg.	270-00149	1
13. SPRING WASHER - 3/8"	027-00393	1
14. NUT - 3/8" UNF	270-00004	1
15. BOLT - 5/16" UNF X 1-1/4" Lg.	270-00620	1
16. PULLEY - Camshaft	201-12840	1
17. KEY - Driving Pulley	027-04057	1
18. GRUB SCREW - Driving Pulley	292-50770	1
19. BELT - End Less 'V', 41" Lg.	292-50770	1
20. STARTER MOTOR - 12 VOLT	000-00717	1
21. NUT - Starter, Brass-Hwx Head, 3/8" UNC 2A	000-00562	1
22. SPRING WASHER - Starter 3/8"	064-02582/E	1
23. NUT - Starter, #8 - 32	101-00600	1
24. SPRING WASHER - Starter	064-02582/A	1
25. BRACKET - Ammeter	000-00365	1
26. AMMETER	000-00030	1
27. SWITCH - Pushbutton	000-00031	1
28. SWITCH - Oil Pressure	000-00033	1
29. ADAPTOR PLUG	000-00899	1
30. ELBOW - 45°	101-00001	1
31. WIRING HARNESS	000-00246	1

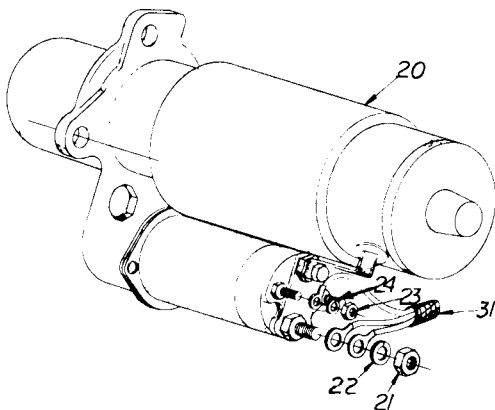
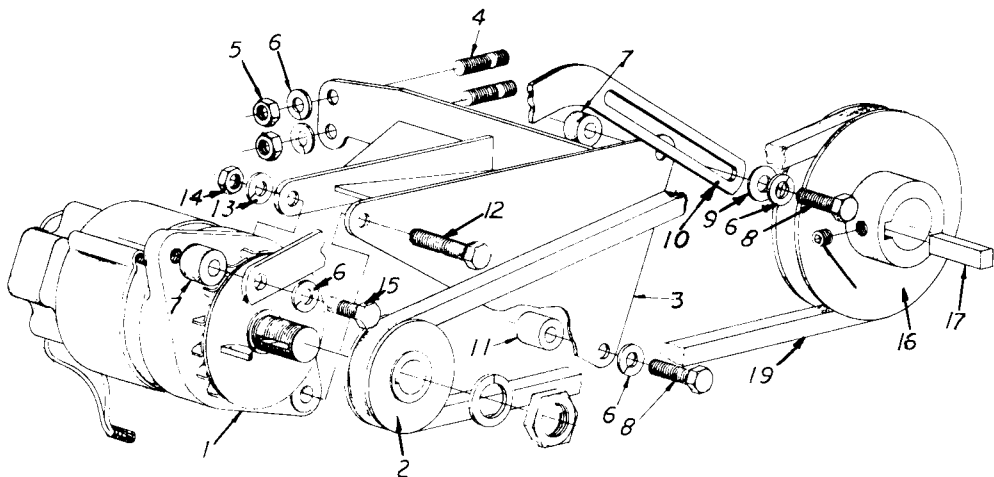

1-2463/13

ELECTRIC STARTING—12 VOLT—MOTOROLA ALTERNATOR & DELCO STARTER—ST1

ST1 ELECTRIC STARTING - 12 VOLT - MOTOROLA ALTERNATOR & DELCO STARTER

12 VOLT ELECTRICAL STARTING KIT - (continued)

	DESCRIPTION	PART NO.	QTY
-	CABLE CLAMP	000-00808	1
-	HOLE PLUG BUTTON	000-01013	1
	BELT GUARD - If needed for above		
	See "Guard" Section for details	998-00150	1

** FOR BUILD 31 ENGINES (12" FAN) USE START MOTOR, PART
NUMBER - 000-01209, B/M - 998-00214.

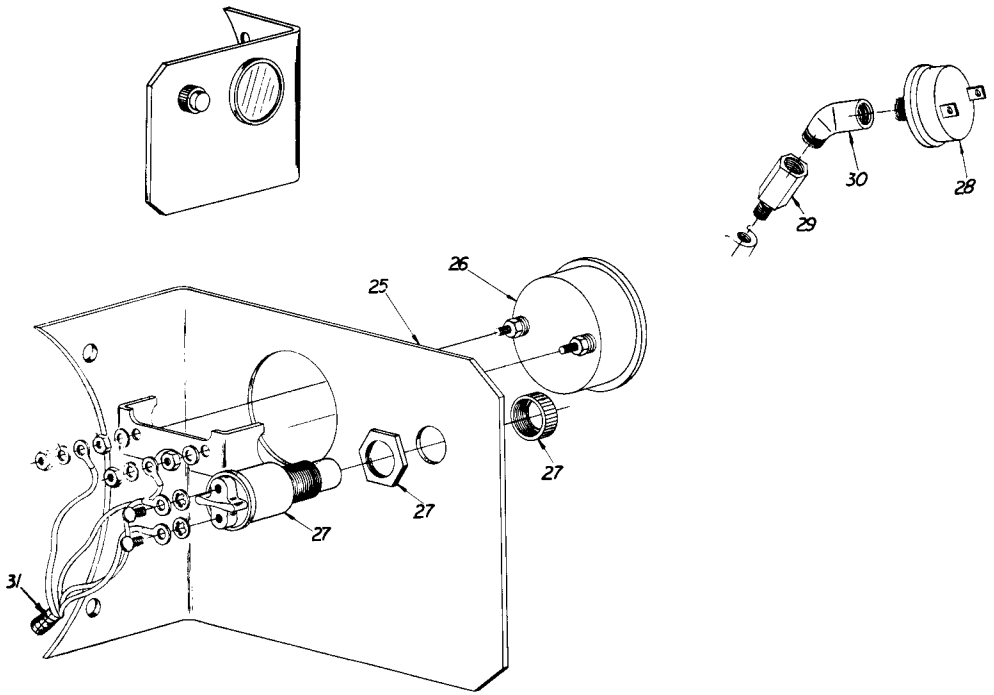

1-2465/14

ELECTRIC STARTING — 12 VOLT — MOTOROLA ALTERNATOR & DELCO STARTER — ST1

ST2/3 ELECTRIC STARTING - 12 VOLT - L.D.1. ALTERNATOR BRACKET

12 VOLT ELECTRICAL STARTING KIT 998-00125

DESCRIPTION	PART NO.	QTY
1. ALTERNATOR - With Fan	000-00032	1
2. DISTANCE PIECE	027-05394	1
3. ADJUSTING LINK - Alternator	000-00878	1
4. PLAIN WASHER - 5/16"	027-00082	5
5. SPRING WASHER - 5/16"	027-00413	5
6. BOLT - 5/16" UNF X 2-3/4" Lg.	270-00068	4
7. BOLT - 5/16" UNC X 1-1/4" Lg.	270-00231	1
8. BRACKET - Alternator Mounting	000-00483	1
9. PULLEY - Alternator	000-00624	1
10. DRIVE BELT	000-00930	1
11. DRIVING PULLEY	000-00357	1
12. KEY - Camshaft Pulley	027-04057	1
13. DISTANCE PIECE	366-03663	3
14. SPRING WASHER - 3/8"	027-00393	2
15. NUT - 3/8"	270-00004	2
16. DISTANCE PIECE - Alternator	000-00485	1
17. STEADY BRACKET - Alternator	000-00484	1
18. BOLT - 3/8" UNF X 3" Lg.	270-00149	2
19. GRUB SCREW - 3/8" UNF X 3/8"	270-00225	1
20. STARTER - 12 Volt	000-00717	1

12 VOLT STARTER FITTING KIT

657-21930

21. DISTANCE PIECE	202-15420	1
22. STUD - 3/8" UNF/UNC X 3" Lg	270-00323	3
23. SPRING WASHER - 3/8"	027-00393	3
24. NUT - 3/8" UNF	270-00004	3
25. NUT - Starter, 3/8" UNC	000-00562	1
26. SPRING WASHER - 3/8"	064-02582/E	1
27. NUT - Starter, #8-32	101-00600	1
28. SPRING WASHER - Starter, #8	064-02582/A	1
29. BRACKET - Ammeter	000-00374	1
30. AMMETER	000-00030	1
31. BUTTON HOLE PLUG - 5/8" Dia.	000-01013	1
32. SWITCH - Push Button	000-00031	1

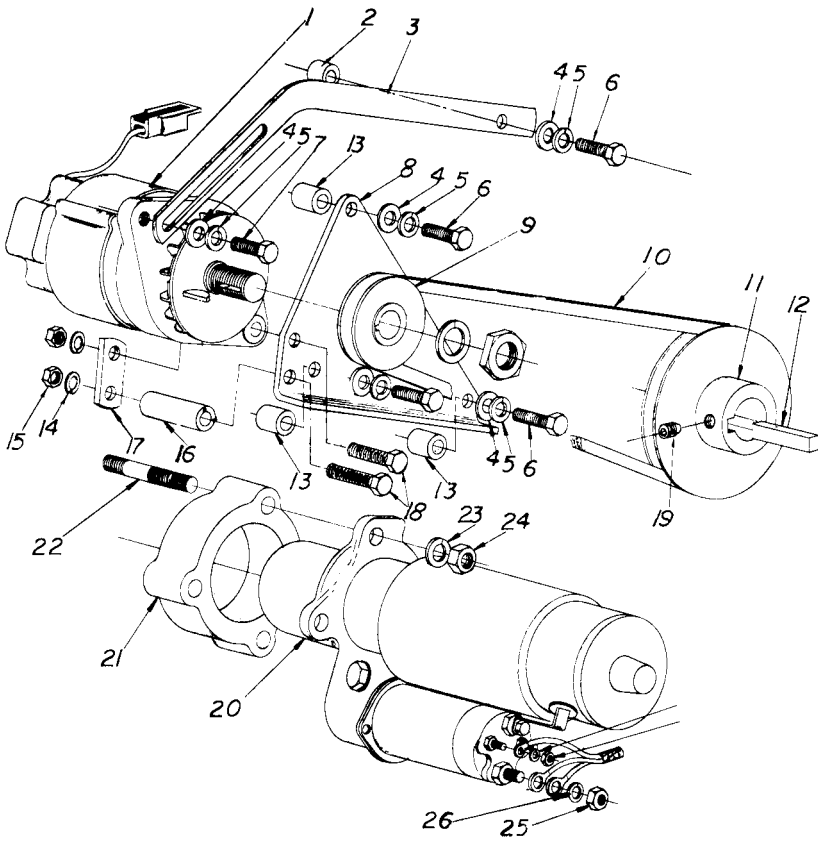

1-2568/15

ELECTRIC STARTING — 12 VOLT — L.D.I. ALTERNATOR BRACKET — ST2/3

ST2/3 ELECTRIC STARTING - 12 VOLT - L.D.1. ALTERNATOR BRACKET

12 VOLT ELECTRICAL STARTING KIT (continued)

	DESCRIPTION	PART NO.	QTY
33.	ADAPTOR - Oil Gallery	000-00899	1
34.	SWITCH - Oil Pressure	000-00033	1
35.	ELBOW - 45°	101-00001	1
36.	PLAIN WASHER - 5/16"	027-00082	2
37.	PLAIN WASHER - 3/8"	027-00184	2
38.	CABLE CLAMP	000-00808	1
39.	WIRING HARNESS	000-00246	1

NOTE: FOR ST2 USE ONLY:

-	FUEL SHIELD	000-00995	1
-	BOLT	270-00055	2
-	PLAIN WASHER - 1/4"	027-00618	2
-	SPRING WASHER - 1/4"	027-00451	2
-	NUT - 1/4" UNF	270-00002	2
-	DISTANCE PIECE	291-33740	1

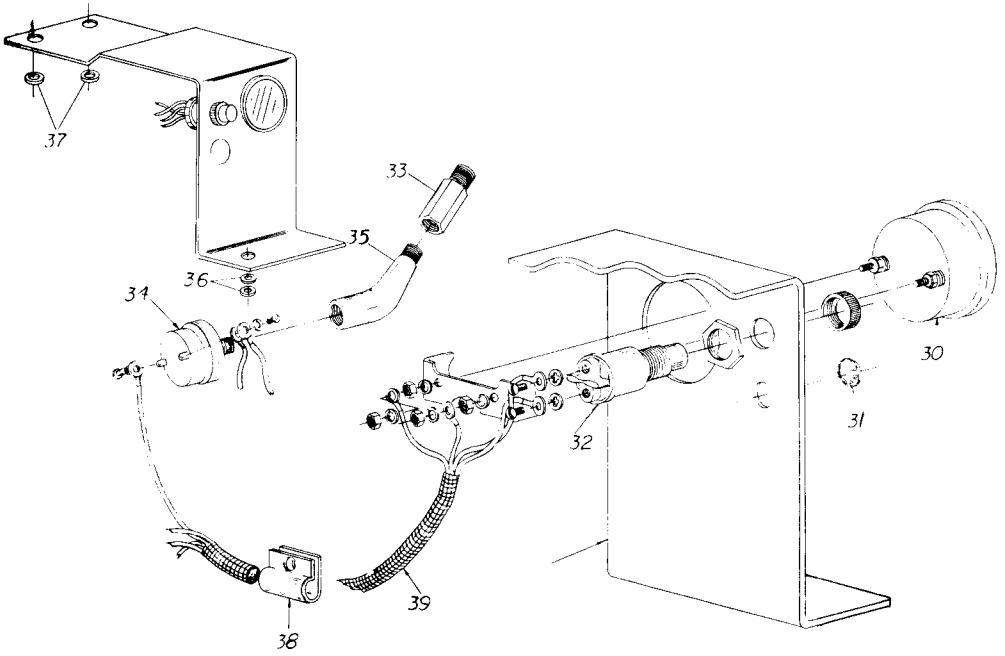

1-2926/16

ELECTRIC STARTING—12 VOLT—L.D.I. ALTERNATOR BRACKET—ST2/3

ST1/2/3 FUEL CONTROL SOLENOID - ENERGIZED TO RUN

ENERGIZED TO RUN SOLENOID KIT 998-00095

	DESCRIPTION	PART NO.	QTY
1.	BRACKET	000-00298	1
2.	SOLENOID - 13 Volt	366-06845	1
3.	NUT - 14" UNF	270-00002	1
4.	CLEVIS	366-06846	1
5.	BOLT - Hex Head, 1/4" UNC X 3/4" Lg.	270-00294	2
6.	NUT - 1/4" UNC	101-00601	2
7.	SPRING WASHER - 1/4"	027-00451	2
8.	SWIVEL	366-06847	1
9.	NUT - #10, 32 UNF	270-0001	4
10.	SPRING WASHER - 3/16"	027-00717	1
11.	SHIM - Spring Adjustment	064-02580/A	5
12.	CONTROL ROD	000-00299	1
13.	PLAIN WASHER - Brass, .185 I.D.	064-02580/D	4
14.	SPLIT COTTER PIN - 3/64" X 3/8" Lg.	027-01986	1
15.	SPACER BUSH	000-00557	1
16.	CONTROL LEVER	000-00608	1
17.	LOCKING DISC	064-31952	1
18.	ADJUSTMENT PLATE	064-08894	1
19.	SCREW - Counter Sink, Brass; 6BA X 5/16" Lg.	064-06616/A	2
23.	SPINDLE	064-08886	1
24.	'O' RING - Spindle	301-13120	1
25.	MOVEMENT LIMIT SPACER	064-09267	1
26.	SPRING - Overload Control	064-32720	1
27.	PAWL	201-12320	1
28.	SPRING WASHER	027-00451	1
29.	NUT	270-00002	1
30.	PLUNGER BARREL	064-31953	1
31.	PIN - Plunger Location	064-09249	1
32.	PLUNGER SPRING	064-07967	1
33.	CONTROL PLUNGER	064-32699	1
34.	SPRING PIN	027-00613	1
35.	BRACKET - Spring Anchor (ST1 only))	000-00303	1

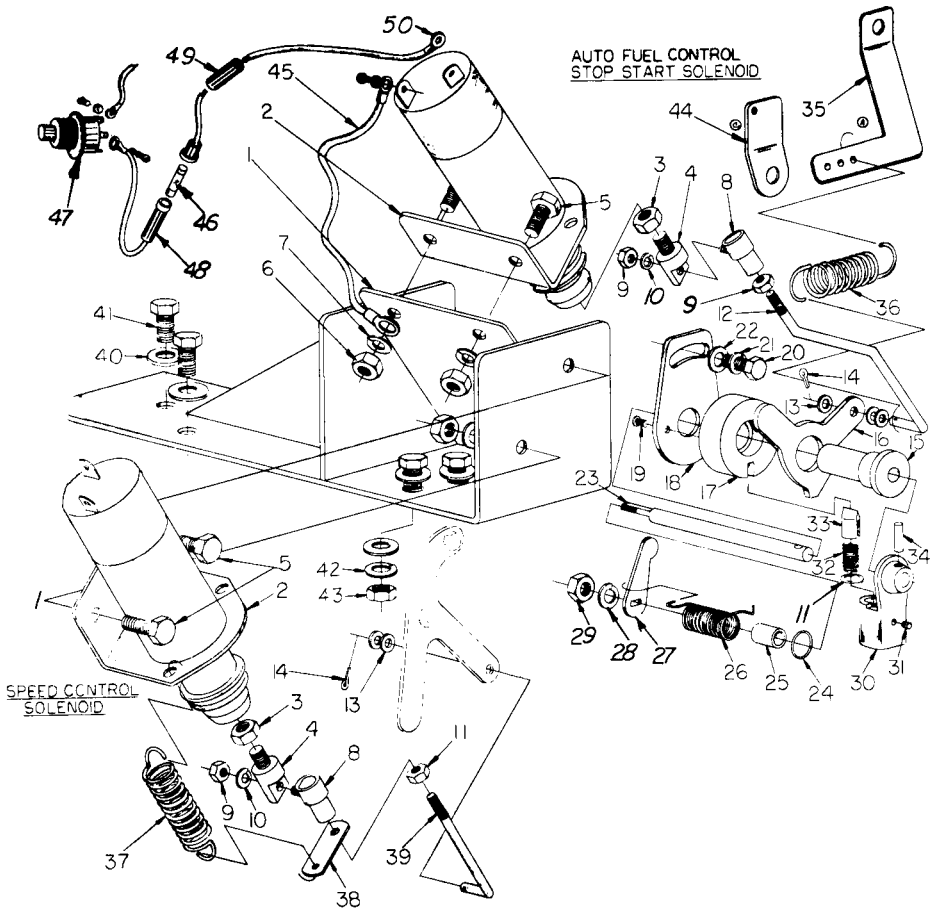

1-2454/8

TWO SPEED CONTROL SOLENOID USING SYNCHRO START—ST1/2/3

ST1/2/3 FUEL CONTROL SOLENOID - ENERGIZED TO RUN

ENERGIZED TO RUN SOLENOID KIT - (continued)

DESCRIPTION	PART NO.	QTY
36. SPRING - Fuel Shutdown	000-00625	1
40. PLAIN WASHER - 5/16"	027-00082	8
41. BOLT - 5/16" UNF X 1" Lg.	270-00061	4
42. SPRING WASHER - 5/16"	027-00413	4
43. NUT - 5/16" UNF	270-00003	4
44. BRACKET - Spring, Anchor (ST2/3)	000-00552	1
45. WIRE LEAD	000-00599	1
46. FUSE - 10 AGC	000-00526	1
47. SWITCH - Shutdown	000-00723	1
- WIRING HARNESS	000-01017	1

LOW LUBE OIL PRESSURE SWITCH FOR USE WITH ABOVE IF NEEDED.

000-00033 1

REPLACEMENT PARTS REQUIRED FOR THIS KIT MUST BE
ACCOMPANIED WITH THE ENGINE SERIAL NUMBER.

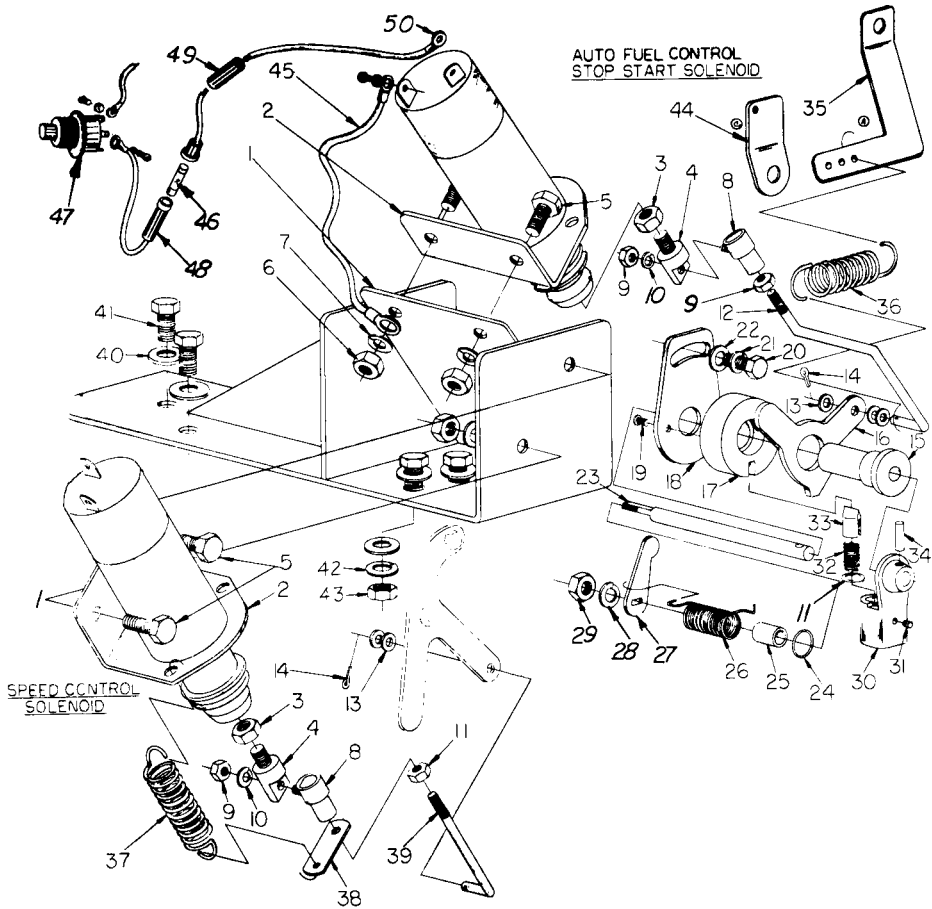

1-2454/8

TWO SPEED CONTROL SOLENOID USING SYNCHRO START—ST1/2/3

ST1/2/3 STOP/START TWO SPEED SOLENOIDS

ENERGIZED TO RUN SOLENOID KIT 998-00071

	DESCRIPTION	PART NO.	QTY
1.	BRACKET	000-00298	1
2.	SOLENOID - 12 Volt	366-06845	2
3.	NUT - 1/4" UNF	270-00002	2
4.	CLEVIS	366-06846	2
5.	BOLT - Hex Head, 1/4" UNC X 3/4" Lg.	270-00294	4
6.	NUT - 1/4" UNC	101-00601	4
7.	SPRING WASHER - 1/4"	027-00451	4
8.	SWIVEL	366-06847	2
9.	NUT - #10, 32 UNF	270-00001	4
10.	SPRING WASHER - 3/16"	027-00717	2
11.	SHIM - Spring Adjustment	064-02580/A	5
12.	CONTROL ROD - Stop/Start	000-00299	1
13.	PLAIN WASHER - Brass, .185 I.D.	064-02580/D	8
14.	SPLIT COTTER PIN - 3/64" X 3/8" Lg.	027-01986	2
15.	SPACER BUSH	000-00557	1
16.	CONTROL LEVER	000-00608	1
17.	LOCKING DISC	064-31952	1
18.	ADJUSTMENT PLATE	064-08894	1
19.	SCREW - Countersink, Brass; 6BA X 5/16" Lg.	064-06616/A	2
23.	SPINDLE	064-08886	1
24.	'O' RING - Spindle	201-13120	1
25.	MOVEMENT LIMIT SPACER	064-09267	1
26.	SPRING - Overload Control	064-32720	1
27.	PAWL	201-12320	1
28.	SPRING WASHER	027-00451	1
29.	NUT	270-00002	1
30.	PLUNGER BARREL	064-31953	1
31.	PIN - Plunger Location	064-09249	1
32.	PLUNGER SPRING	064-07967	1
33.	CONTROL PLUNGER	064-32699	1
34.	SPRING PIN	027-00613	1
35.	BRACKET - Spring Anchor (ST1)	000-00303	1

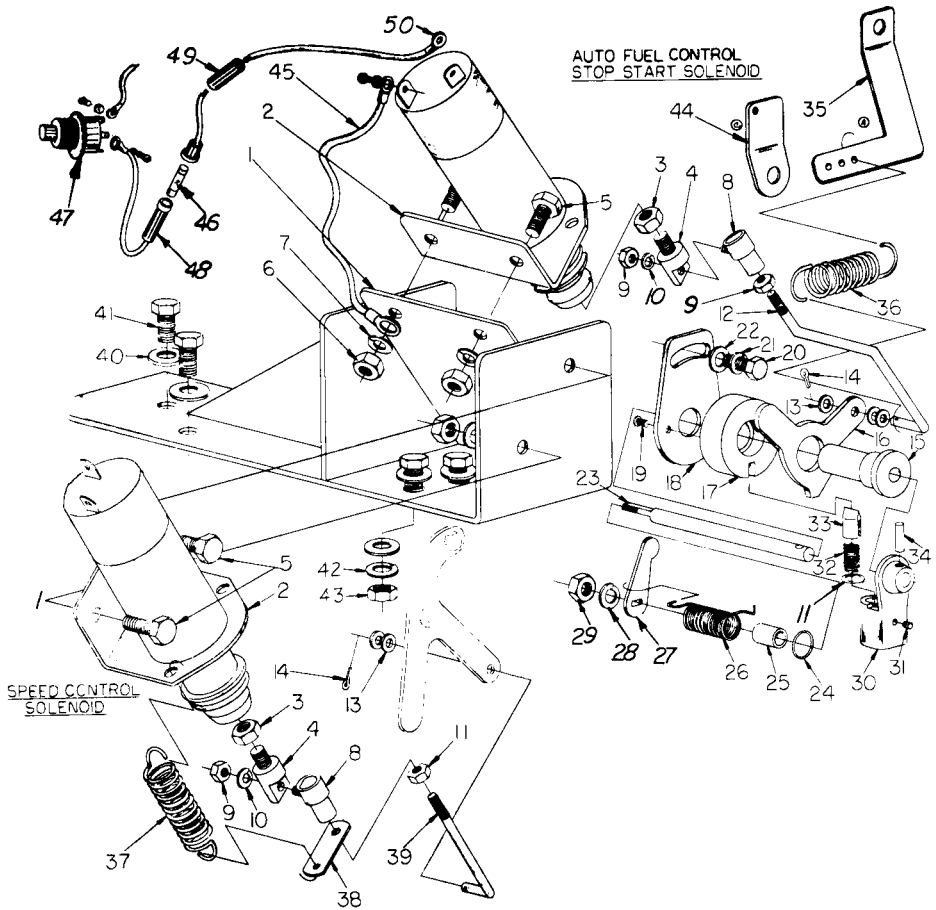

1-2454/8

TWO SPEED CONTROL SOLENOID USING SYNCHRO START—ST1/2/3

ST1/2/3 STOP/START TWO SPEED SOLENOIDS

ENERGIZED TO RUN SOLENOID KIT - (continued)

	DESCRIPTION	PART NO.	QTY
36.	SPRING - Fuel Shutdown	000-00625	1
37.	SPRING - Speed Control	000-00370	1
38.	BRACKET - Spring Anchor	000-00627	1
39.	CONTROL ROD - Speed Control	000-00300	1
40.	PLAIN WASHER - 5/16"	027-00082	8
41.	BOLT - 5/16" UNF X 1" Lg.	270-00061	4
42.	SPRING WASHER - 5/16"	027-00413	4
43.	NUT - 5/16" UNF	270-00003	4
44.	BRACKET - Spring Anchor (ST2/3 only)	000-00552	1
45.	WIRE LEAD	000-00599	2
46.	FUSE - 10 AGC	000-00526	2
47.	SWITCH - Shutdown	000-00723	1
48.	FUSE HOLDER	101-00405	1
49.	BUTT CONNECTOR	101-00404	1
50.	TERMINAL	101-00402	1
-	WIRING HARNESS	000-01017	1

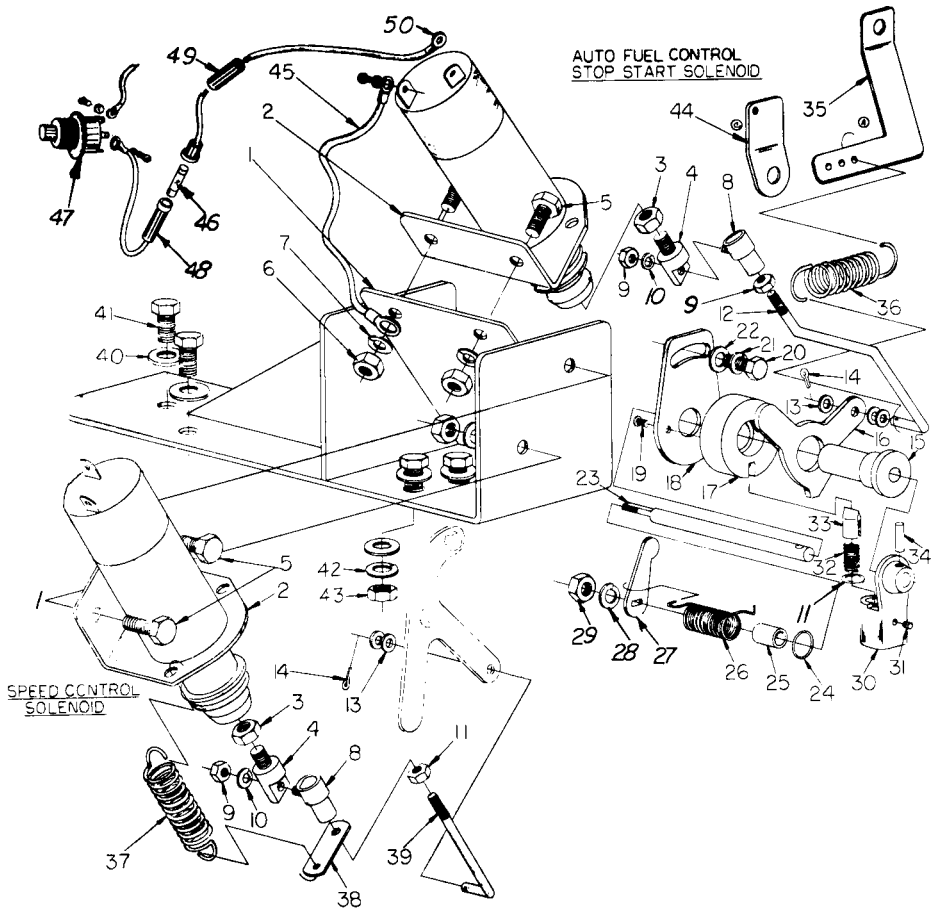

1-2454/8

TWO SPEED CONTROL SOLENOID USING SYNCHRO START—ST1/2/3

ST1/2/3 TWO SPEED CONTROL SOLENOID USING SYNCHRO START

TWO SPEED CONTROL SOLENOID USING SYNCHRO START KIT 998-00113

	DESCRIPTION	PART NO.	QTY
1.	BRACKET	000-00298	1
2.	SOLENOID	366-06845	1
3.	NUT - 1/4" UNF	270-00002	1
4.	CLEVIS	366-06846	1
5.	BOLT - 1/4" UNC X 3/4"	270-00294	2
6.	NUT - 1/4" UNC	101-00601	3
7.	WASHER - 1/4"	027-00451	2
8.	SWIVEL	366-06847	1
9.	NUT - #10, 32 UNF	270-00001	2
10.	SPRING WASHER - 3/16"	027-00717	1
12.	CONTROL ROD	000-00300	1
13.	WASHER - Brass,. 185 I.D	064-02580/D	3
14.	SPLIT PIN	027-01986	1
37.	SPRING - Speed Control	000-00370	1
38.	SPRING - Anchor	000-00627	1
40.	WASHER - 5/16"	027-00082	4
41.	BOLT - 5/16" UNF	270-00061	4
42.	SPRING WASHER - 5/16"	027-00413	4
43.	NUT - 5/16" UNF	270-00003	4
45.	WIRE LEAD	000-00599	1
47.	SWITCH - Shutdown	000-00723	1
	WIRING HARNESS ASSEMBLY	000-01017	
46.	FUSE - 10 AGC	000-00526	1
48.	FUSE HOLDER	101-00405	1
49.	BUTT CONNECTOR	101-00402	1
50.	TERMINAL	101-00404	1

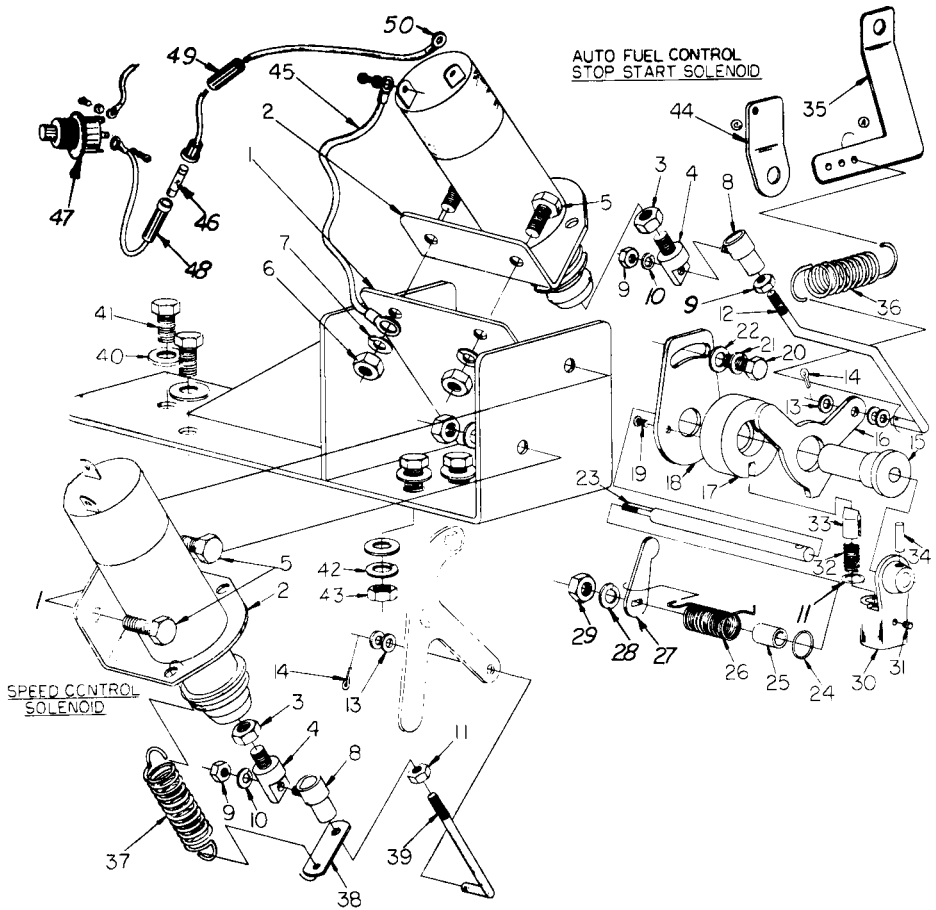

1-2454/8

TWO SPEED CONTROL SOLENOID USING SYNCHRO START—ST1/2/3

ST1/2/3 FUEL CONTROL SOLENOID - ENERGIZED TO STOP

ENERGIZED TO STOP SOLENOID KIT 998-00101

	DESCRIPTION	PART NO.	QTY
1.	BRACKET - Solenoid Mounting	000-00466	1
2.	SOLENOID	366-06845	1
3.	NUT - 1/4" UNF	000-00615	1
4.	CONNECTOR - Solenoid	366-06846	1
5.	BOLT - Hex Head, 1/4" UNC X 3/4" Lg.	270-00285	2
6.	NUT - 1/4" UNC	000-00615	2
7.	SPRING WASHER - 1/4"	027-00451	2
8.	TRIP LEVER	000-00467	1
9.	PLAIN WASHER - 4BA	064-06612/B	3
10.	CLEVIS PIN	000-00269	2
11.	SPLIT PIN	064-06722/C	2
12.	ROCKING LEVER ASSEMBLY	064-09694	1
13.	PLAIN WASHER - 1/4"	027-00418	15
14.	LOCKNUT - 1/4" UNF	270-00153	1
15.	CONTROL LINK	064-09687	1
16.	CONTROL LEVER ASSEMBLY	064-09705	1
17.	PLAIN WASHER - 4BA	064-06612/B	2
18.	SPLIT COTTER PIN	064-06722/C	1
19.	SPRING	064-09688	1
20.	BOLT - Hex Head, 1/4" UNF X 1" Lg.	270-00056	3
21.	WIRING HARNESS	000-00750	1
22.	LOW OIL PRESSURE SAFETY SWITCH - NORMALLY CLOSED, 4 P.S.I	000-00628	1
23.	SOLENOID DISCONNECT SWITCH - NORMALLY OPEN, 2 P.S.I.	000-00594	1

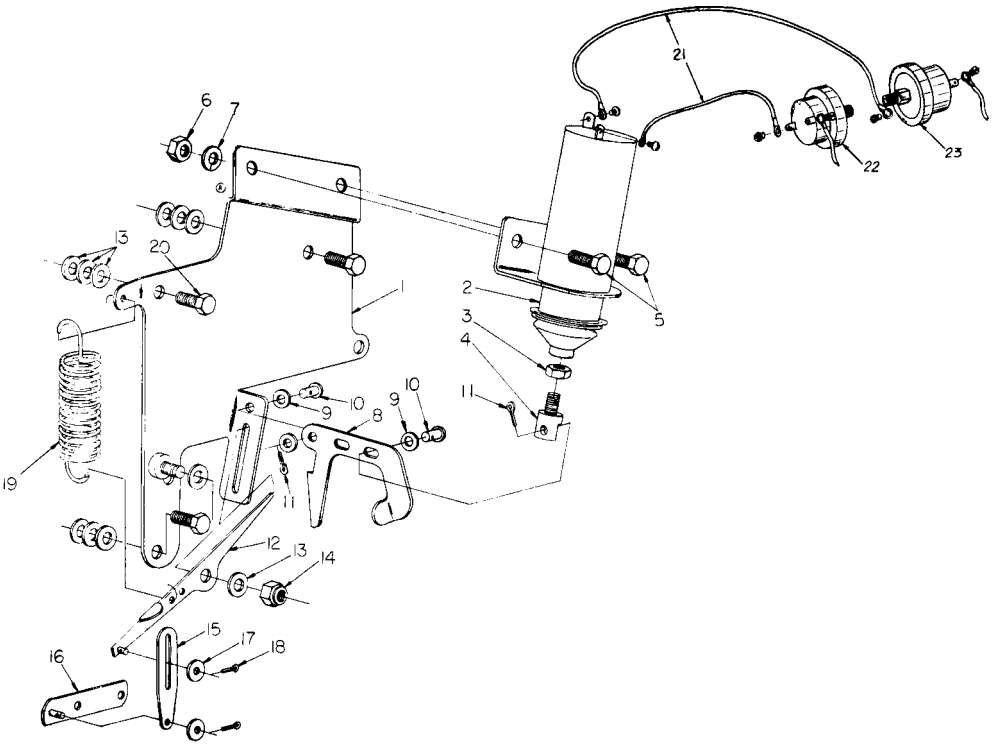

1-2450/10

FUEL CONTROL SOLENOID—ENERGIZED TO RUN—ST1/2/3

ST1/2 FUEL INLET AND RETURN CONNECTORS

FUEL INLET AND RETURN CONNECTORS TO 1/8" FEMALE N.P.T 998-00123

	DESCRIPTION	PART NO.	QTY
1.	FUEL PUMP INLET CONNNECTOR	000-00568	1
2.	FUEL RETURN CONNECTOR	000-00567	1
3.	GASKET	600-00106	1

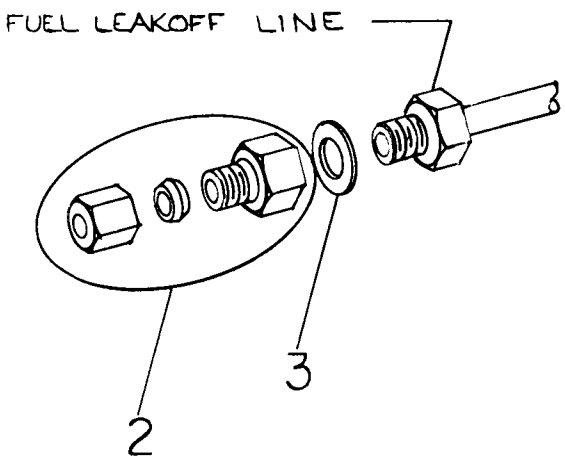
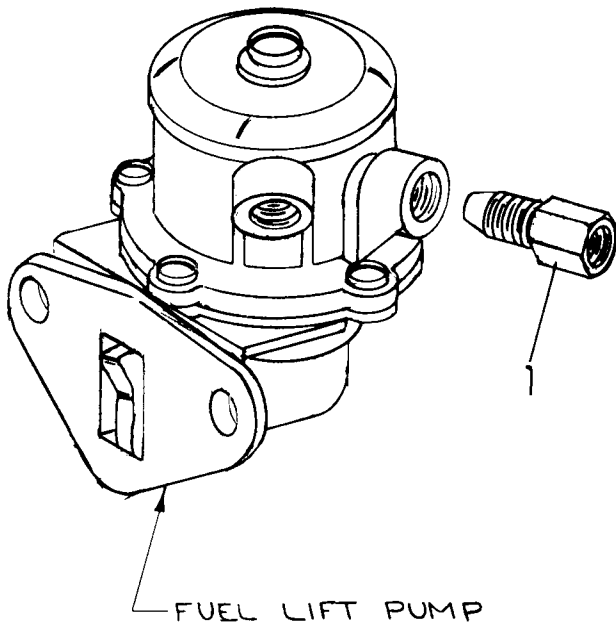

1-2947/24

FUEL INLET AND RETURN CONNECTORS—ST1/2

ST1 GUARD FOR MOTOROLA ALTERNATOR

ALTERNATOR DRIVE GUARD 998-00150

	DESCRIPTION	PART NO.	QTY
1.	GUARD ASSEMBLY	366-06632	1
2.	STUD 5/16" UNF	366-06653	1
3.	BOLT - 1/4" UNF X 1/2"	270-00054	2
4.	SPRING WASHER - 1/4"	027-00451	2
5.	WASHER - 1/4"	027-00618	2
6.	NUT - 5/16" UNF	027-00003	2
7.	LOCK WASHER - 5/16"	027-00413	2
8.	PLAIN WASHER - 5/16"	027-00082	2
9.	BRACKET	366-06638	1
10.	BRACKET ASSEMBLY	366-06669	1

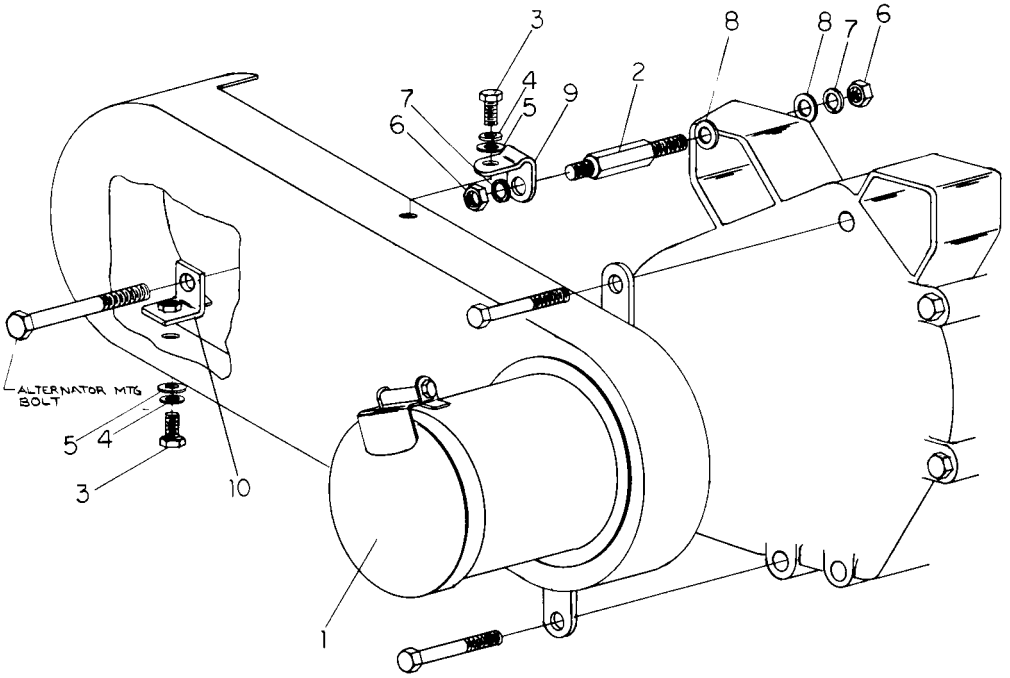

1-2793/23

GUARD FOR MOTOROLA ALTERNATOR—ST1

ST1 GUARD FOR MOTOROLA ALTERNATOR

ALTERNATOR DRIVE GUARD, LDI ALTERNATOR ARRANGEMENT

(W/SHAFT GUARD) ST2/3 998-00200

	DESCRIPTION	PART NO.	QTY
1.	BELT DRIVE GUARD ASSEMBLY	000-00825	1
2.	BRACKET - Side Fitting	000-01176	1
3.	BRACKET - Bottom Fitting	000-00704	1
4.	BOLT - 1/4" UNF X 5/8"	270-00023	3
5.	SPRING WASHER - 1/4"	027-00451	3
6.	BRACKET - Top	000-01211	1
7.	STUD - 5/16" UNF	366-06653	1
8.	SPRING WASHER	027-00413	2
9.	NUT - 5/16" UNF	270-00003	2

ST1/2/3 TACHOMETER - HOURMETER

TACHOMETER - HOUR METER KIT 998-00013

	DESCRIPTION	PART NO.	QTY
1.	TACHOMETER - Hour Meter, 12 Volt	000-00005	1
2.	A. C. TAP	000-00042	1

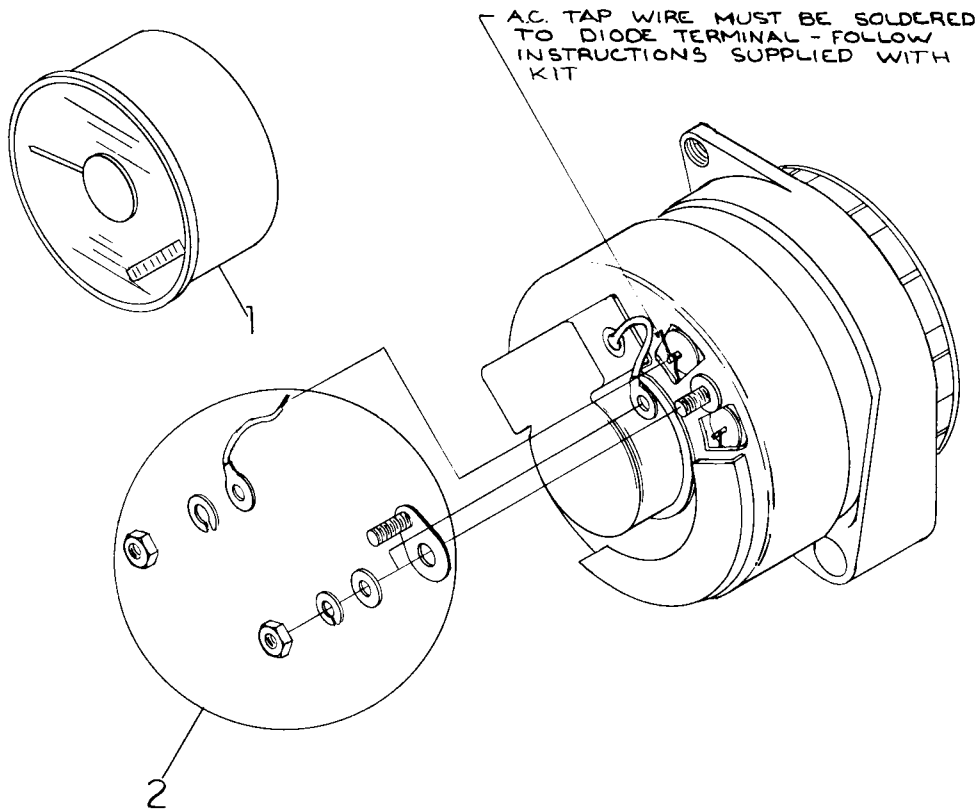

NOTE - HEAD SHIPPED LOOSE

1-2923/17

TACHOMETER—HOUR METER KIT—ST1/2/3

ST1/2/3 LUBE OIL PRESSURE GALLERY KIT

LUBE OIL PRESSURE GALLERY KIT 998-00001

	DESCRIPTION	PART NO.	QTY
1.	OIL GALLERY	000-00595	1
2.	PIPE PLUG - 1/8" NPT	101-00002	1
3.	ELBOW - 1/8" NPT To 1/4" Tube	101-00200	2
4.	INSERT - 1/4"	101-00204	2
5.	NYLON TUBE - 1/5" X 12" Lg.	101-00604	1
6.	JOINT	291-26090	1

LUBE OIL PRESSURE GAUGE KIT 998-00005

	DESCRIPTION	PART NO.	QTY
-	GAUGE - Pressure, 0-80 P.S.I	000-00635	1
-	ADAPTOR	000-00899	1
-	ELBOW - 45° Street, 1/8" NPT	101-00001	1

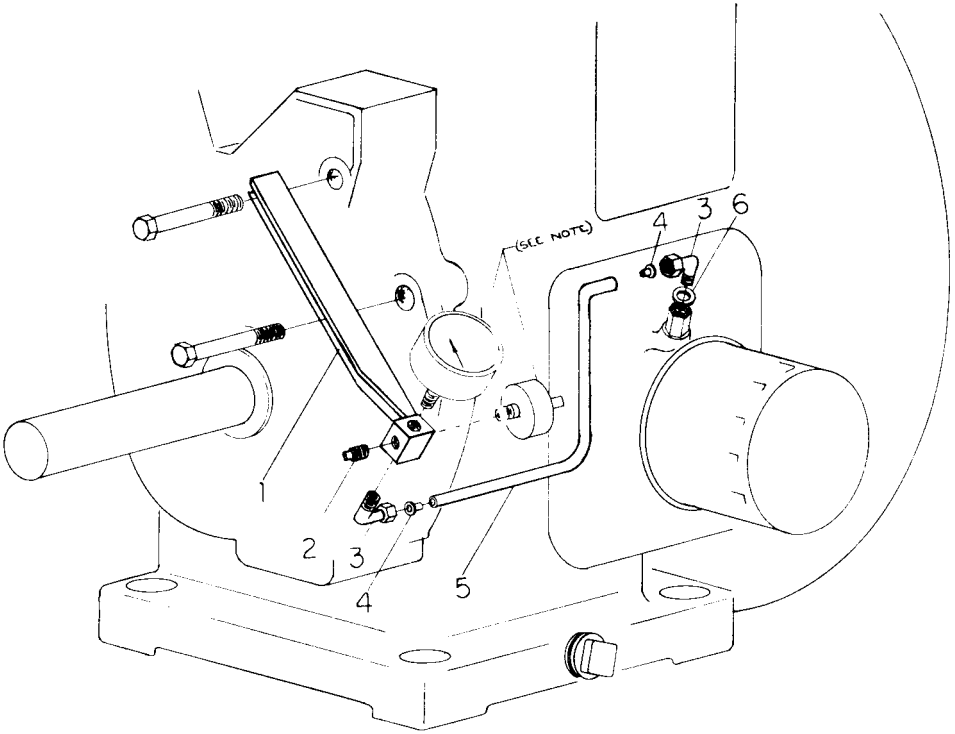

NOTE: THIS BILL OF MAT'L TO BE USED ONLY WITH OTHER BILLS OF MAT'L. PARTS SHOWN ARE OPTIONAL EQUIPMENT ON OTHER B/M'S.

1-2878/11

LUBE OIL PRESSURE GALLERY KIT—ST1/2/3

ST1/2/3 HIGH AIR TEMPERATURE SWITCHES

HIGH AIR TEMPERATURE SWITCH KIT - N/O - FOR USE WITH ENERGIZED TO STOP 998-00142

	DESCRIPTION	PART NO.	QTY
1.	SWITCH - Temperature, N/O	000-00688	1

HIGH AIR TEMPERATURE SWITCH KIT - N/C 998-00134

	DESCRIPTION	PART NO.	QTY
1.	SWITCH - Temperature, N/C	000-00606	1

ABOVE KITS WITH THE FOLLOWING:

	DESCRIPTION	PART NO.	QTY
1.	SWITCH - Temperature	See Above	1
2.	BOLT - Hex Head, 3/8" UNC X 2-3/4" Lg.	000-00839	1
3.	POP RIVET - 1/8" Short	000-00671	2
4.	MOUNTING BRACKET - Switch	000-00658	1
5.	DISTANCE PIECE - Switch	000-00659	1
6.	PLAIN WASHER - 3/8"	000-00630	1
7.	PLAIN WASHER - 3/8"	027-00184	1
8.	SPRING WASHER - 3/8"	027-00393	1
9.	NUT - 3/8" UNC	101-00605	1

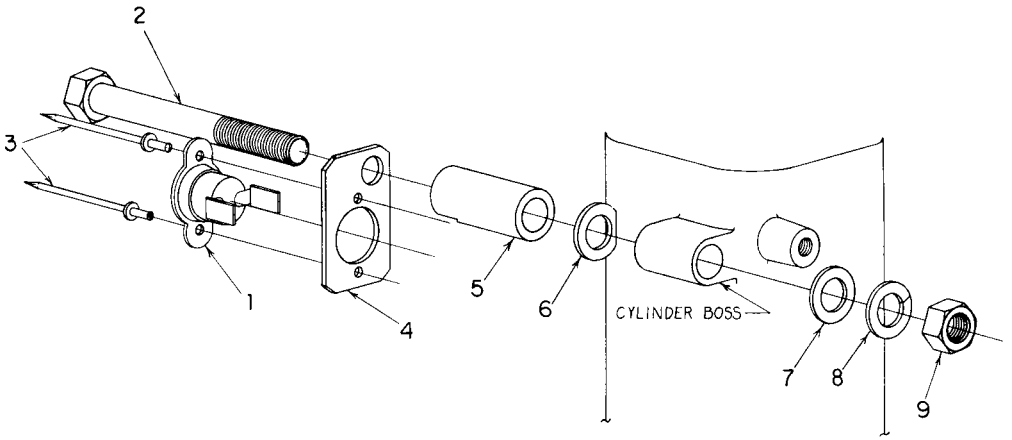

1-2870/9

HIGH AIR TEMPERATURE SWITCHES—ST1/2/3

ST1/2/3 HIGH AIR TEMPERATURE SWITCHES

VARIABLE SPEED CONTROL KIT 998-00014

	DESCRIPTION	PART NO.	QTY
	GOVERNOR WEIGHT - 2600 R.P.M.	572-11662	2
1.	MOUNTING BRACKET - Handle	000-00858	1
2.	CONTROL CABLE ASSEMBLY	000-00013	1
3.	LOCK NUT	N.P.N.	1
4.	NUT - Locking	000-00199	2
5.	CABLE PIVOT & ANCHOR	000-00200	1
6.	HOLDER - Cable	366-04972	1
7.	PLAIN WASHER - 1/4"	027-00618	2
8.	NUT - 5/16" UNF	270-00003	1
9.	SPRING WASHER - 5/16"	027-00413	1

VARIABLE SPEED CONTROL LESS GOVERNOR WEIGHTS PER B/M 998-00189.

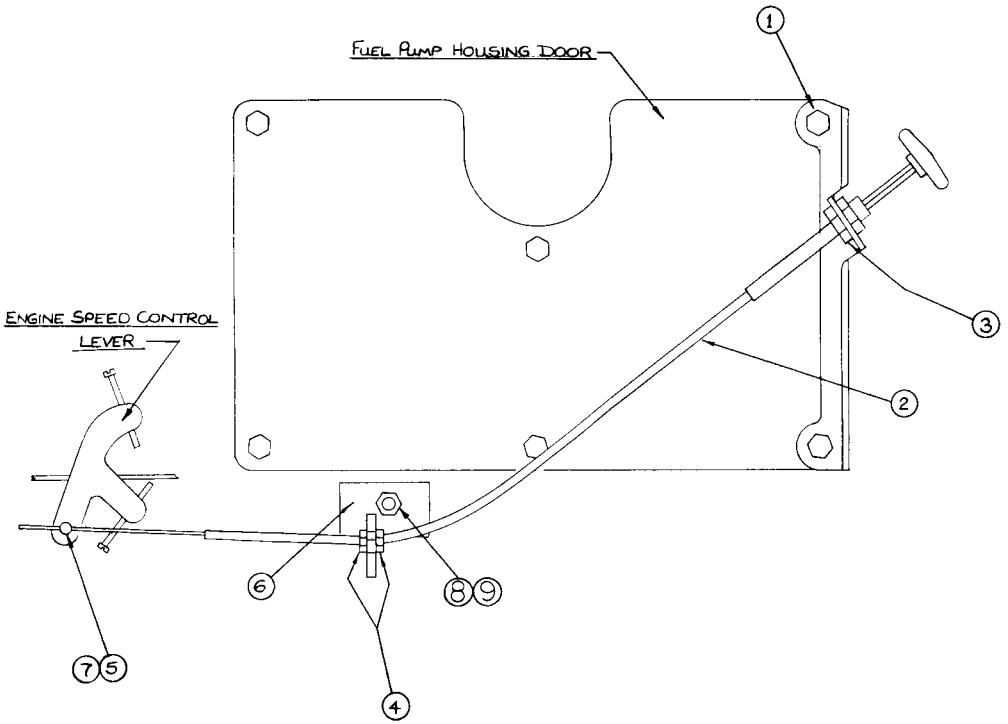

1-2782/18

VARIABLE SPEED CONTROL — CABLE OPERATED — ST1/2/3

