

ALPHA RANGE SUPPLEMENTARY ACCESSORY PARTS LIST

INDEX

DESCRIPTION	KIT NO.	PAGE
AIR CLEANERS		
5 1/4" ENGINE-MOUNTED AIR CLEANER	989-00132	6
ADAPTORS		
ONAN 'YD' STYLE ADAPTOR	989-00055	8
SAE #5 TO SAE #4 ADAPTOR	898-00113	8
FLYWHEEL END P.T.O.		
C106 CLUTCH	989-00006	10
C107 CLUTCH	989-00007	10
SHAFT EXTENSION		
1 7/16" DIAMETER	989-00008	12
1 1/2" DIAMETER	989-00053	12
ONAN 'YD' STYLE	989-00054	12
SEMI-FINISHED	989-00153	12
HYDRAULIC PUMP DRIVES		
FLYWHEEL END		
SAE 'A' 8-TOOTH SPLINE	989-00253	14
SAE 'A' 9-TOOTH SPLINE	989-00012	14
SAE 'A' 11-TOOTH SPLINE	989-00300	14
SAE 'A' 13-TOOTH SPLINE	989-00142	14
SAE 'A' 5/8" SHAFT	989-00093	14
SAE 'A' 11/16" SHAFT	989-00199	16
SAE 'A' 3/4" SHAFT	989-00034	16
SAE 'A' 7/8" SHAFT	989-00182	16
SAE 'B' 11-TOOTH SPLINE	989-00099	16
SAE 'B' 15-TOOTH SPLINE	989-00293	16
SAE 'B' 15-TOOTH C.I. ADAPTOR	989-00304	16

ALPHA RANGE SUPPLEMENTARY ACCESSORY PARTS LIST

INDEX

DESCRIPTION	KIT NO.	PAGE
HYDRAULIC PUMP DRIVES (CONT.)		
FLYWHEEL END (CONT.)		
SAE 'B' 7/8" SHAFT	989-00102	16
SAE 'B' 1" SHAFT	989-00101	18
SAE 'C' 14-TOOTH SPLINE	989-00073	18
SAE 'C' 21-TOOTH SPLINE	989-00205	18
GEAR END		
SAE 'A' 9-TOOTH SPLINE	989-00009	20
SAE 'A' 11-TOOTH SPLINE	989-00211	20
SAE 'A' 13-TOOTH SPLINE	989-00010	20
SAE 'A' 7/8" SHAFT	989-00111	20
COOLING SYSTEM		
LARGE CRANKSHAFT PULLEY	989-00074	22
LOW-PROFILE RADIATOR	989-00018	24
SUPER-LOW-PROFILE RADIATOR	989-00123	26
CRANKSHAFT MOUNTED FANS	989-00148	28
	989-00149	28
WATER-PUMP MOUNTED FANS		
PUSHER FAN	989-00284	28
PULLER FAN	989-00285	30
RADIATOR GUARD 2,3 CYL.	989-00023	30
RADIATOR GUARD 4 CYL.	989-00063	30

ALPHA RANGE SUPPLEMENTARY ACCESSORY PARTS LIST

INDEX

DESCRIPTION	KIT NO.	PAGE
STARTING & CHARGING		
61 AMP DELCO ALTERNATOR	989-00175	32
STARTING AIDS		
ENGINE COOLANT HEATER	989-00087	34
ETHER START KIT	989-00279	34
CONTROLS		
VERNIER SPEED CONTROL CABLE	989-00157	36
INSTRUMENTS & PANELS		
TEMP. GAUGE & SENDER	989-00005	38
OIL PRESSURE GAUGE & SENDER	989-00004	38
RATIONALISED PANEL	989-00057	40
LOW PANEL MOUNT	989-00058	42
HIGH PANEL MOUNT	989-00059	42
START PANEL W/2 LAMPS, ENG. MOUNT	989-00138	44
START PANEL W/2 LAMPS, REM. MOUNT	989-00139	44
PROTECTION DEVICES		
TEMPERATURE SWITCH	000-06175	46
OIL PRESSURE SWITCH	000-05659	46
2-WIRE ETR SOLENOID	000-00297	46
3-WIRE ETR SOLENOID	000-00290	46
24-VOLT ETR SOLENOID	000-00302	46

This page is intentionally left blank

This page is intentionally left blank

ALPHA RANGE AIR CLEANERS

5¼" ENGINE-MOUNTED AIR CLEANERS 989-00132

	DESCRIPTION	PART NO.	QTY.
1.	AIR CLEANER	000-01493	1
2.	REPLACEMENT ELEMENT	602-41760	-
3.	MOUNTING BAND	382-04373	2
4.	MOUNTING BRACKET	000-05675	1
5.	BOLT M8 X 16	272-00038	8
6.	NUT M8	272-00017	4
7.	SPRING WASHER M8	272-00071	8
8.	HOSE BEND	000-05699	1
9.	HOSE CLAMP	027-04234	2

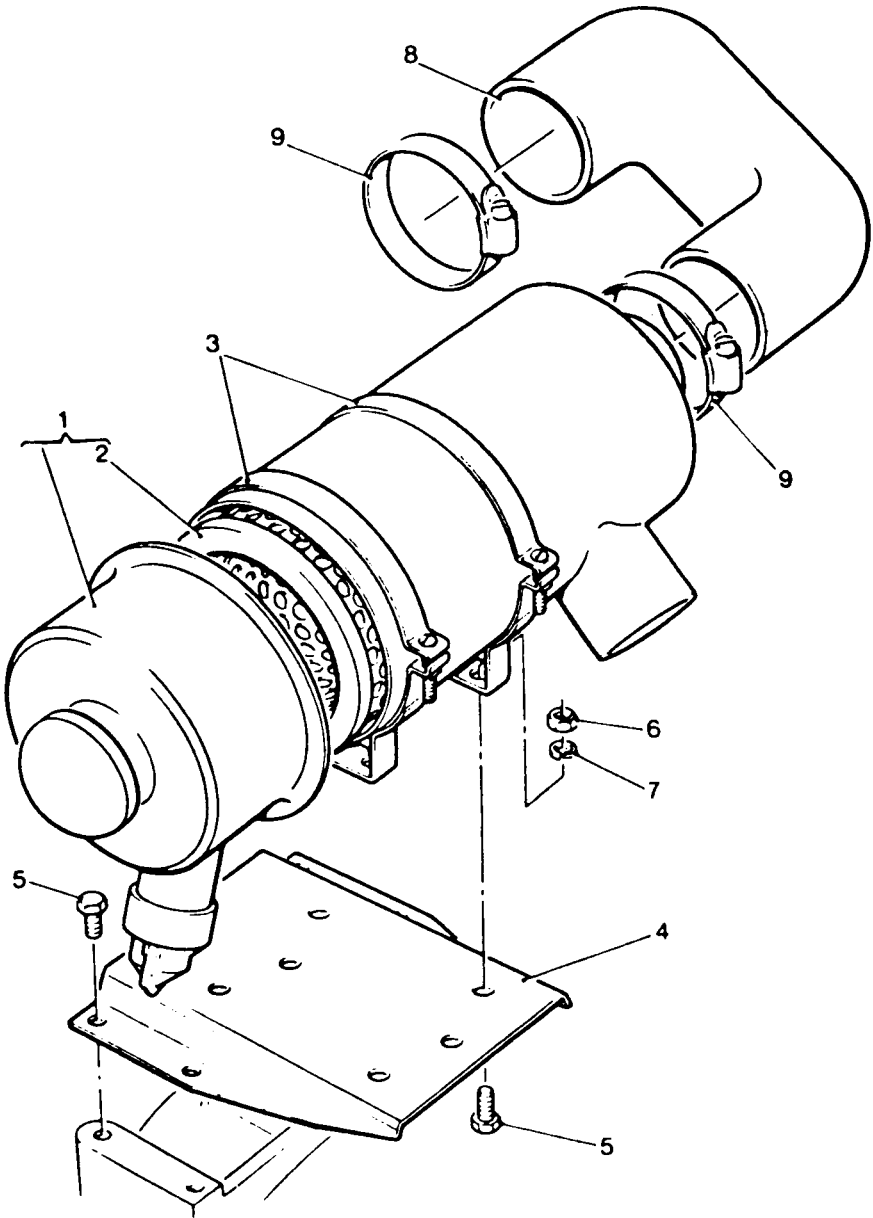

ALPHA RANGE AIR CLEANERS — LPA, LPW/S

ALPHA RANGE ADAPTORS

ONAN 'YD' STYLE ADAPTOR 989-00555

	DESCRIPTION	PART NO.	QTY.
1.	ADAPTOR	000-03952	1
2.	PLAIN WASHER 3/8	027-00184	8
3.	SPRING WASHER 3/8	027-00393	8
4.	SOC. HD. BOLT 3/8 UNC 1 3/4	101-00623	8

SAE#5 TO #4 ADAPTOR 989-00113

	DESCRIPTION	PART NO.	QTY.
1.	ADAPTOR	000-05521	1
3.	SPRING WASHER 3/8	027-00393	8
4.	SOC. HD. BOLT 3/8 UNC X1	000-05954	8
	NOT SHOWN:		
	BOLT M8 X 30	272-00041	2
	DISTANCE PIECE	366-03663	2

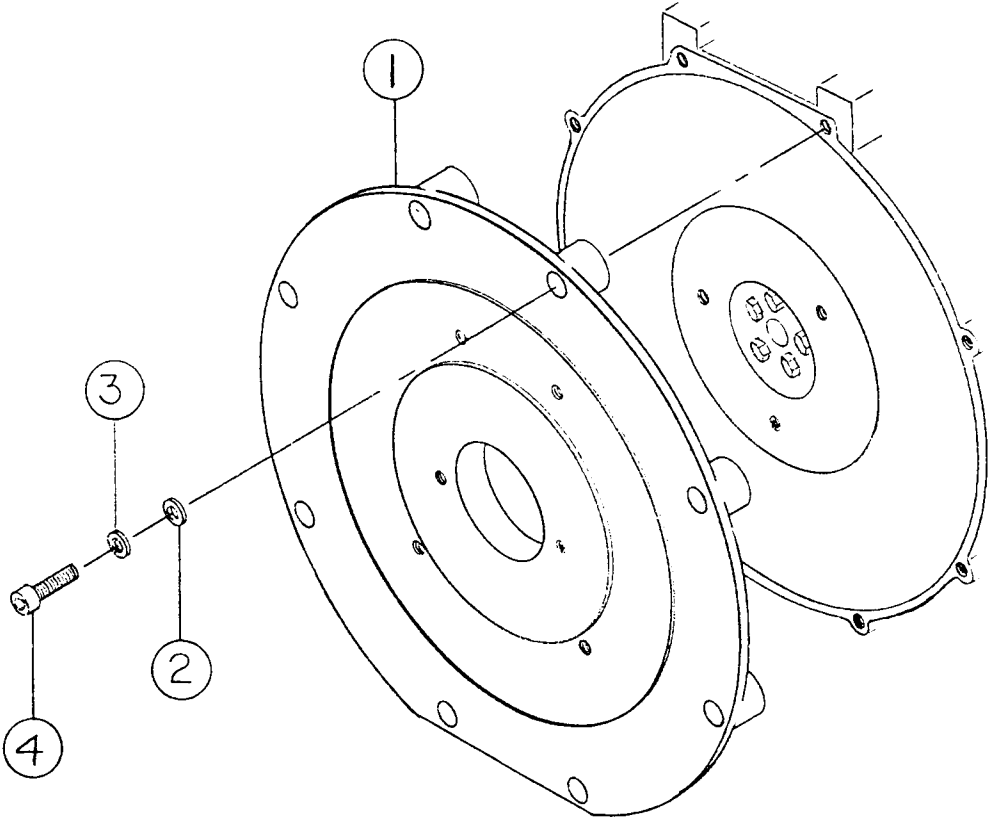

ALPHA RANGE ADAPTORS - LPA, LPW/S

ALPHA RANGE FLYWHEEL END P.T.O.

C106 CLUTCH 989-00006

	DESCRIPTION	PART NO.	QTY.
1.	CLUTCH	000-00060	1
2.	ADAPTOR	750-10480	1
3.	DRIVE MEMBER	750-10440	1
4.	SPRING WASHER 3/8	027-00393	8
5.	SPRING WASHER 5/16	027-00413	6
6.	NUT 3/8 UNF	270-00004	8
7.	STUD	270-00248	8
8.	BOLT 5/16 UNC X1 1/4	270-00620	6

C107 CLUTCH 989-00007

	DESCRIPTION	PART NO.	QTY.
1.	CLUTCH	000-01592	1
2.	ADAPTOR	750-10480	1
3.	DRIVE MEMBER	750-11050	1
4.	SPRING WASHER 3/8	027-00393	8
5.	SPRING WASHER 5/16	027-00413	8
6.	NUT 3/8 UNF	270-00004	8
7.	STUD	270-00248	8
8.	BOLT 5/16 UNC X 1 1/4	270-00620	8

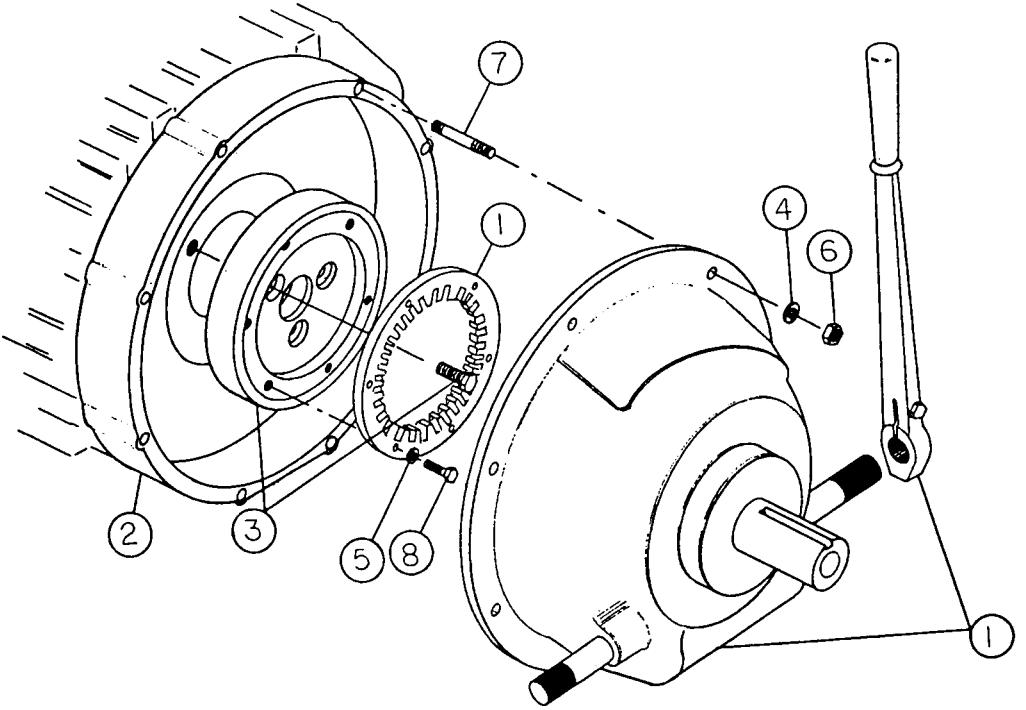

ALPHA RANGE FLYWHEEL END P.T.O. - LPA, LPW/S

ALPHA RANGE FLYWHEEL END P.T.O.

1 7/16 DIA. SHAFT EXTENSION 989-00008

	DESCRIPTION	PART NO.	QTY.
1.	SHAFT EXTENSION	000-04188	1
2.	BOLT M10 X 35	272-00692	3
3.	SPRING WASHER M10	272-00072	3
	NOT SHOWN:		
4.	3/8 SQUARE KEY	000-04480	1

1½ DIA. SHAFT EXTENSION 989-00053

	DESCRIPTION	PART NO.	QTY.
	AS 989-00008 ABOVE, EXCEPT:		
1.	SHAFT EXTENSION	000-04999	1

ONAN 'YD' SHAFT EXTENSION 989-00054

	DESCRIPTION	PART NO.	QTY.
1.	SHAFT EXTENSION	000-03683	1
2.	BOLT M10 X 35	272-00692	3
3.	SPRING WASHER M10	272-00072	3

SEMI-FINISHED SHAFT EXTENSION 989-00153

	DESCRIPTION	PART NO.	QTY.
1.	SHAFT EXTENSION	000-05779	
2.	BOLT M10 X 35	272-00692	
3.	SPRING WASHER M10	272-00072	

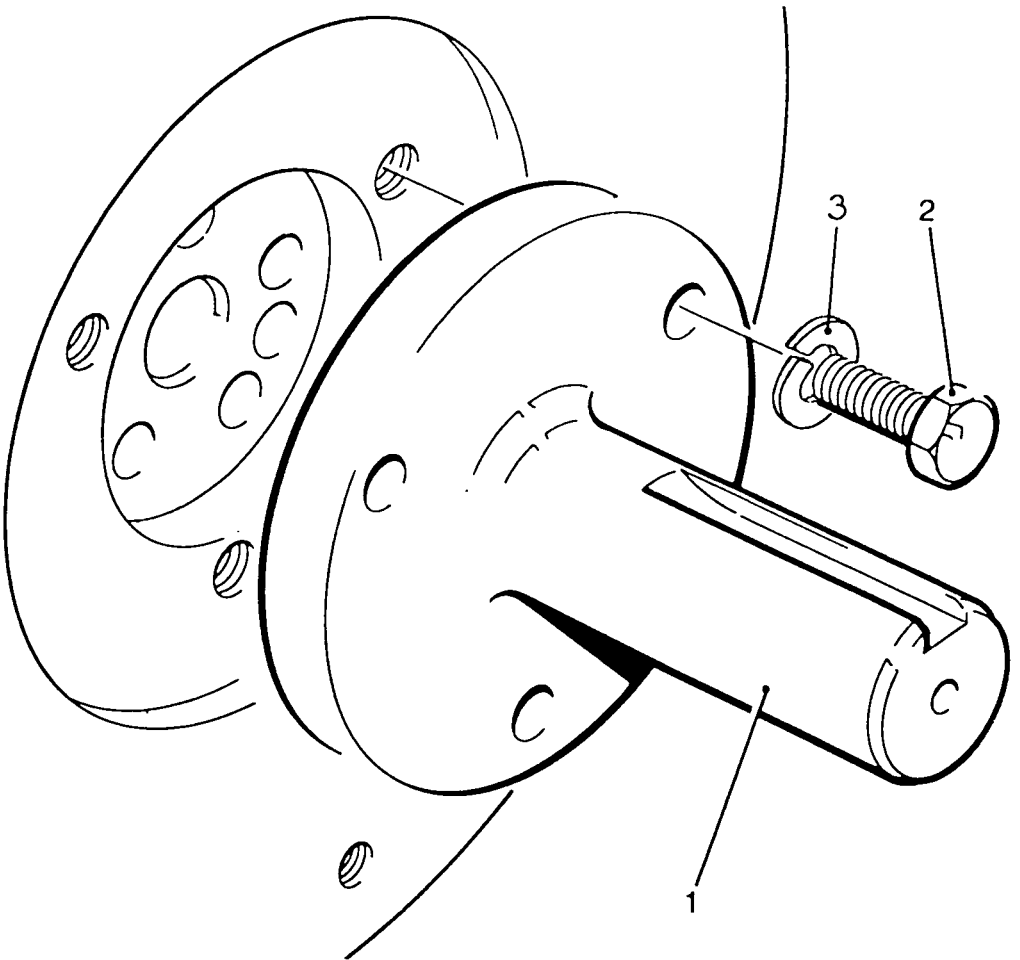

ALPHA RANGE FLYWHEEL END P.T.O. - LPA, LPW/S

ALPHA RANGE FLYWHEEL END HYDRAULIC DRIVES

THE FOLLOWING PARTS ARE COMMON TO ALL KITS LISTED BELOW:

	DESCRIPTION	PART NO.	QTY.
2.	DRIVE MEMBER	000-04305	1
4.	SPRING WASHER 3/8	027-00393	3
5.	BOLT M10 X 40	272-00673	3
7.	WASHER	272-00694	8
8.	BOLT 3/8 UNC X 1 1/4	270-00349	8

SAE 'A', 8-TOOTH SPLINE 989-00253

	DESCRIPTION	PART NO.	QTY.
1.	ADAPTOR	000-04296	1
3.	SPLINED HUB	000-06781	1
6.	SOC. HD. BOLT M10 X 35	272-00206	1

SAE 'A', 9-TOOTH SPLINE 989-00012

	DESCRIPTION	PART NO.	QTY.
1.	ADAPTOR	000-04296	1
3.	SPLINED HUB	000-04306	1
6.	SOC. HD. BOLT M10 X 35	272-00206	1

SAE 'A', 11-TOOTH SPLINE 989-00300

	DESCRIPTION	PART NO.	QTY.
1.	ADAPTOR	000-04296	1
3.	SPLINED HUB	000-05302	1
6.	SOC. HD. BOLT M10 X 35	272-00206	1

SAE 'A', 13-TOOTH SPLINE 989-00142

	DESCRIPTION	PART NO.	QTY.
1.	ADAPTOR	000-04296	1
3.	SPLINED HUB	000-05303	1
6.	SOC. HD. BOLT M10 X 35	272-00206	1

SAE 'A', 5/8" PARALLEL SHAFT 989-00093

	DESCRIPTION	PART NO.	QTY.
1.	ADAPTOR	000-04296	1
3.	DRIVE HUB	000-05207	1

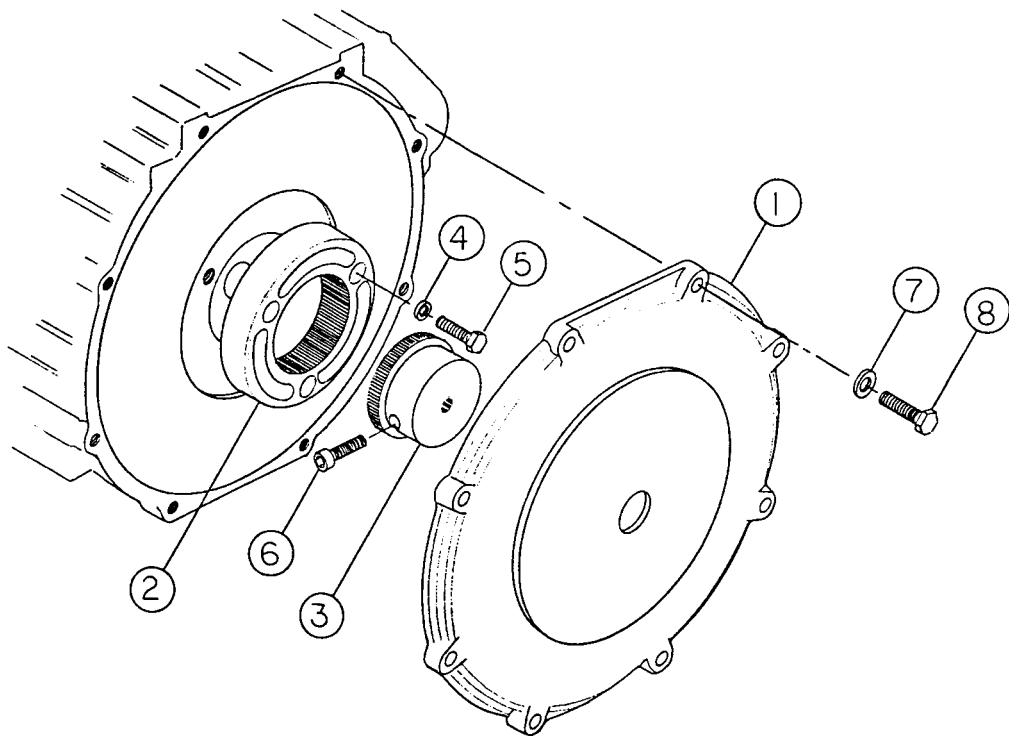

ALPHA RANGE FLYWHEEL END HYDRAULIC DRIVES - LPA, LPW/S

ALPHA RANGE FLYWHEEL END HYDRAULIC DRIVES

SAE 'A', 11/16" PARALLEL SHAFT 989-00199

	DESCRIPTION	PART NO.	QTY.
1.	ADAPTOR	000-04296	1
3.	DRIVE HUB	000-06390	1

SAE 'A', 3/4" PARALLEL SHAFT 989-00034

	DESCRIPTION	PART NO.	QTY.
1.	ADAPTOR	000-04296	1
3.	DRIVE HUB	000-04527	1

SAE 'A', 7/8" PARALLEL SHAFT 989-00182

	DESCRIPTION	PART NO.	QTY.
1.	ADAPTOR	000-04296	1
3.	DRIVE HUB	000-05351	1

SAE 'B', 11-TOOTH SPLINE 989-00099

	DESCRIPTION	PART NO.	QTY.
1.	ADAPTOR	000-05335	1
3.	SPLINED HUB	000-05302	1
6.	SOC. HD. BOLT M10 X 35	272-00206	1

SAE 'B', 15-TOOTH SPLINE 989-00293

	DESCRIPTION	PART NO.	QTY.
1.	ADAPTOR	000-07088	1
3.	SPLINED HUB	000-07087	1
6.	SOC. HD. BOLT M10 X 35	272-00206	1

SAE 'B', 15-TOOTH SPLINE, CAST IRON ADAPTOR 989-00304

	DESCRIPTION	PART NO.	QTY.
	AS 989-00293 ABOVE, EXCEPT:		
1.	ADAPTOR	000-06726	1

SAE 'B', 7/8" PARALLEL SHAFT 989-00102

	DESCRIPTION	PART NO.	QTY.
1.	ADAPTOR	000-05335	1
3.	DRIVE HUB	000-05351	1

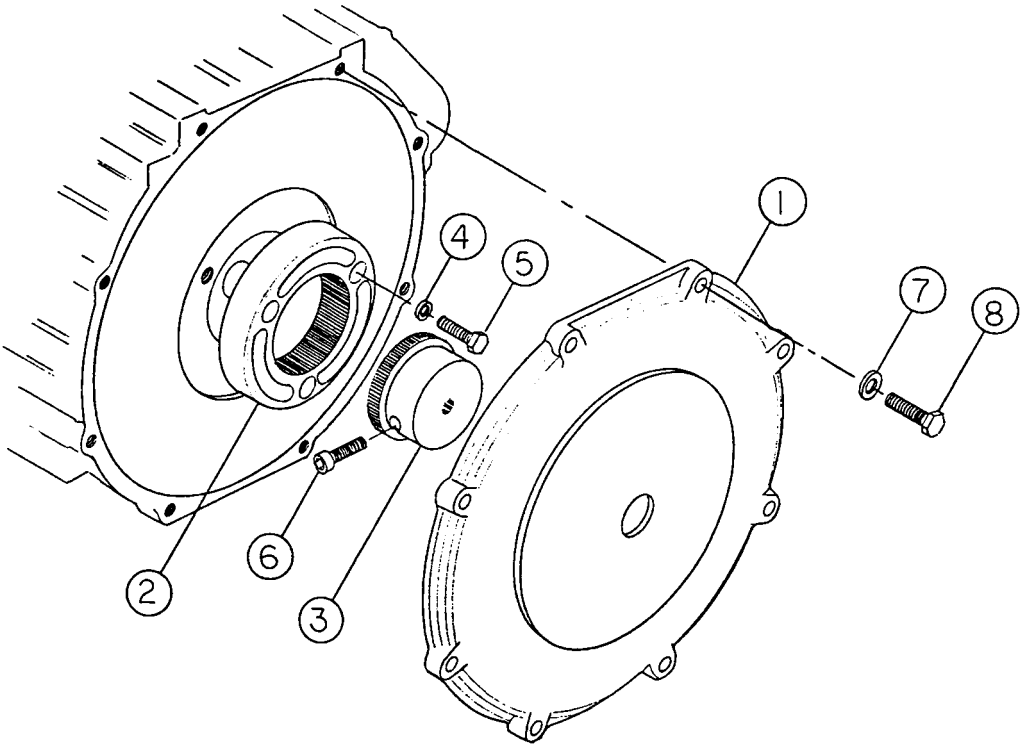

ALPHA RANGE FLYWHEEL END HYDRAULIC DRIVES - LPA, LPW/S

ALPHA RANGE FLYWHEEL END HYDRAULIC DRIVES

SAE 'B', 1" PARALLEL SHAFT 989-00101

	DESCRIPTION	PART NO.	QTY.
1.	ADAPTOR	000-05335	1
3.	DRIVE HUB	000-05336	1

SAE 'C', 14-TOOTH SPLINE 989-00073

	DESCRIPTION	PART NO.	QTY.
1.	ADAPTOR	000-04837	1
3.	SPLINED HUB	000-04838	1
6.	SOC. HD. BOLT M10 X 35	272-00206	1

SAE 'C', 21-TOOTH SPLINE 989-00205

	DESCRIPTION	PART NO.	QTY.
1.	ADAPTOR	000-04837	1
3.	SPLINED HUB	000-06376	1
6.	SOC. HD. BOLT M10 X 35	272-00206	1

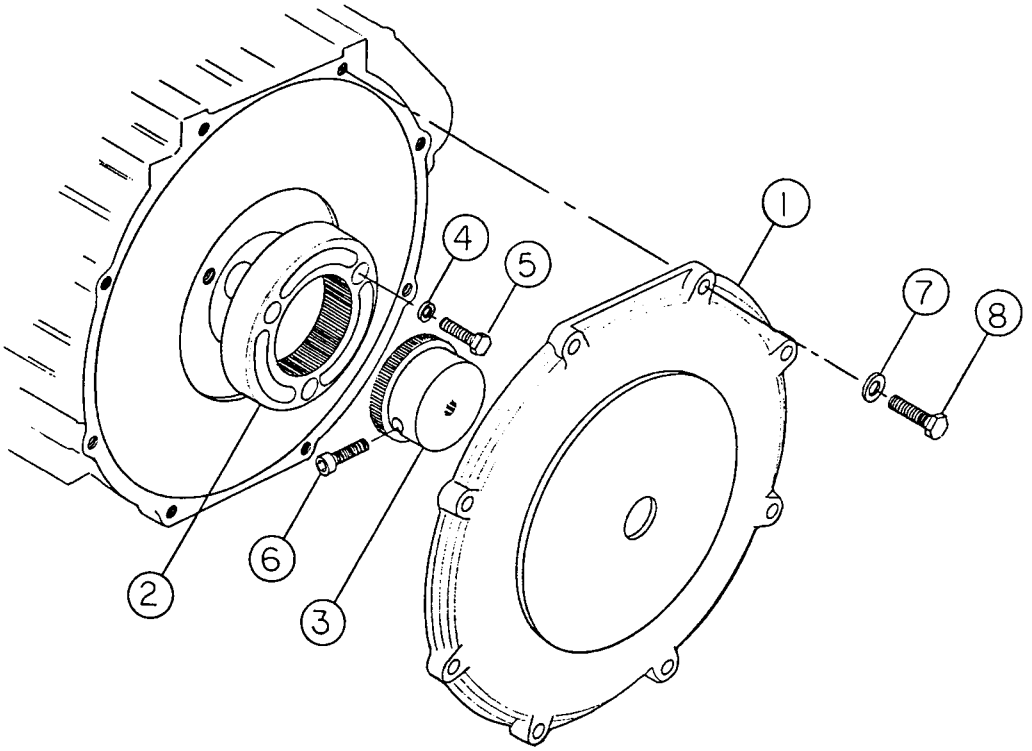

ALPHA RANGE FLYWHEEL END HYDRAULIC DRIVES - LPA, LPW/S

ALPHA RANGE GEAR END HYDRAULIC DRIVES

SAE 'A', 9-TOOTH SPLINE 989-00009

	DESCRIPTION	PART NO.	QTY.
1.	SPLINED HUB	000-04098	1

SAE 'A', 11-TOOTH SPLINE 989-00211

	DESCRIPTION	PART NO.	QTY.
1.	SPLINED HUB	000-06418	1

SAE 'A', 13-TOOTH SPLINE 989-00010

	DESCRIPTION	PART NO.	QTY.
1.	SPLINED HUB	000-04209	1

SAE 'A', 7/8" PARALLEL SHAFT 989-00111

	DESCRIPTION	PART NO.	QTY.
1.	DRIVE HUB	000-05466	1

THE FOLLOWING PARTS ARE COMMON TO ALL KITS LISTED ABOVE:

	DESCRIPTION	PART NO.	QTY.
2.	DRIVE FLANGE	000-04401	1
3.	ELEMENT	000-04402	1
4.	SOC. HD. BOLT M8 X 20	272-00243	4
5.	PUMP MOUNTING	750-41080	1

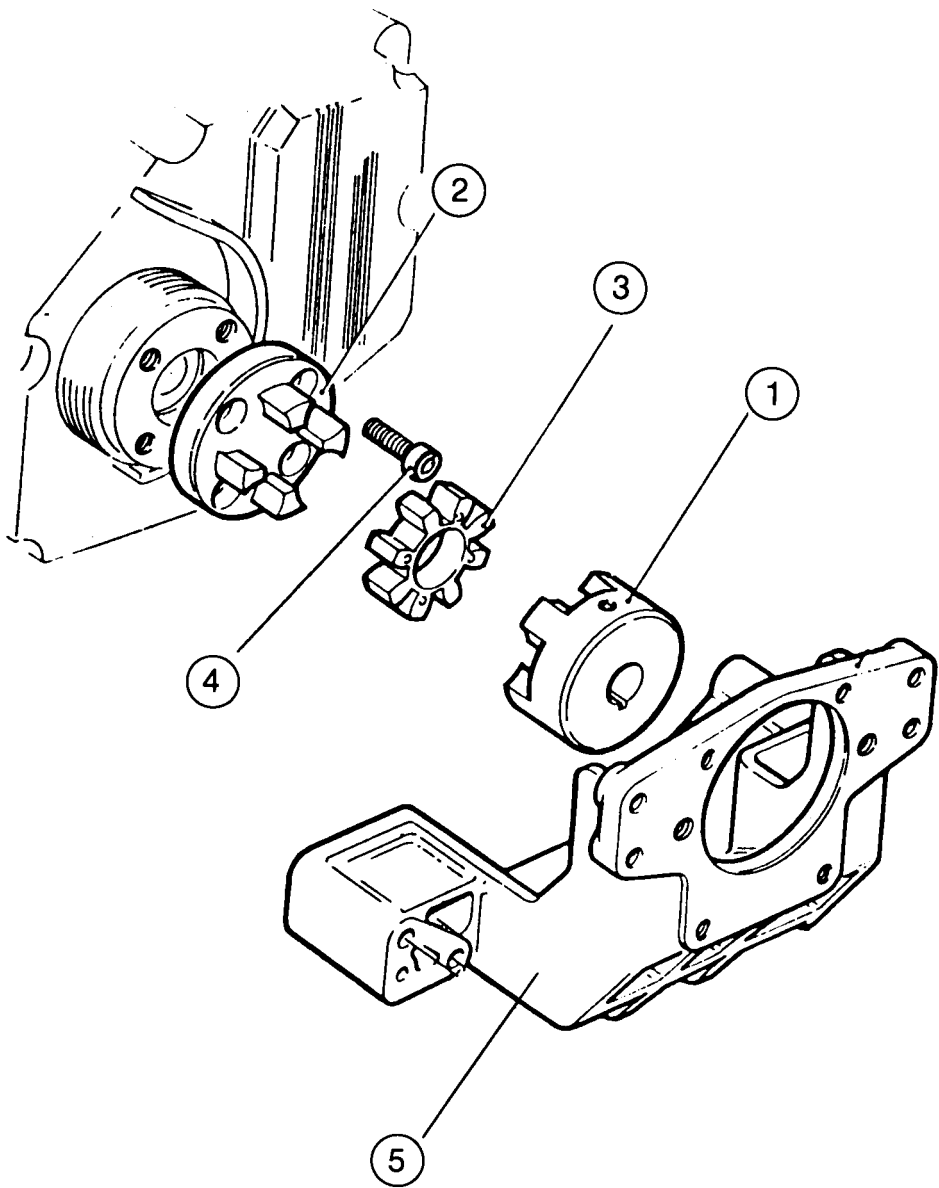

ALPHA RANGE GEAR END HYDRAULIC DRIVES — LPA, LPW/S

ALPHA RANGE COOLING SYSTEM

LARGE CRANKSHAFT PULLEY, LPW/S 989-00074

	DESCRIPTION	PART NO.	QTY.
1.	POLY-V BELT	000-04853	1
2.	CRANKSHAFT PULLEY	751-10408	1
3.	ALTERNATOR PULLEY	751-10965	1

NOTE: THIS ACCESSORY IS FOR USE ONLY AT ENGINE SPEEDS BELOW 2800 RPM.
HORSEPOWER REQUIREMENT TO DRIVE COOLING FAN INCREASES SIGNIFICANTLY.

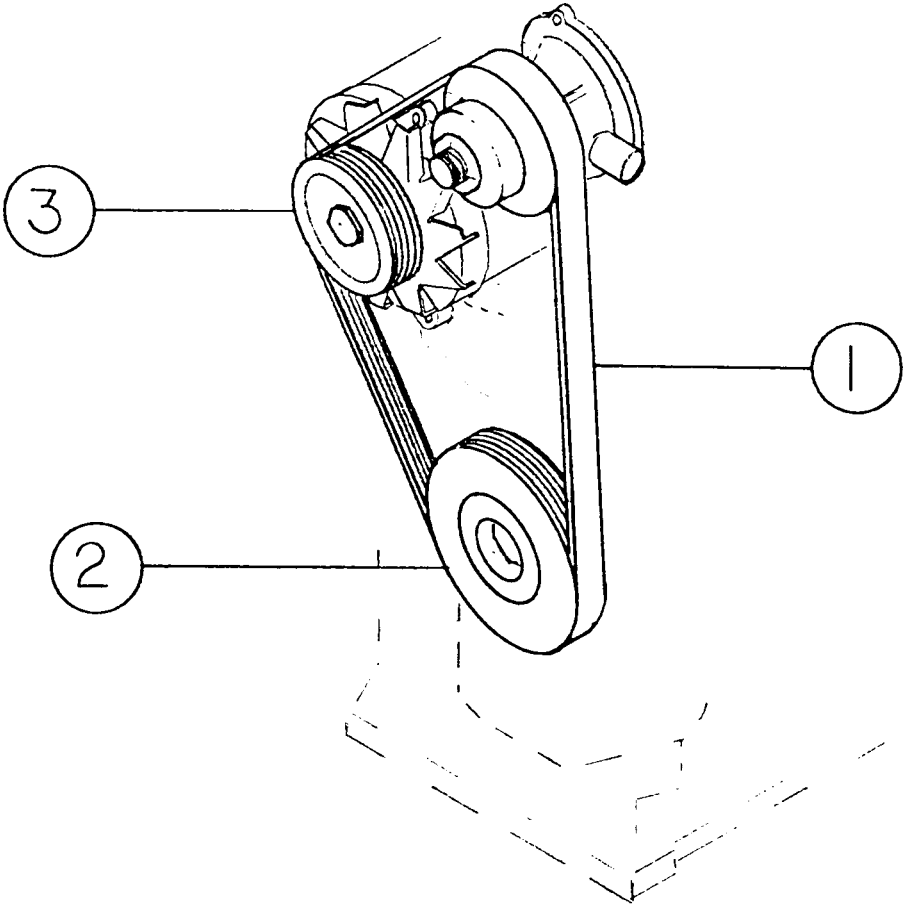

ALPHA RANGE COOLING SYSTEM — LPW/S

ALPHA RANGE COOLING SYSTEM

LOW PROFILE RADIATOR, LPW/S4 989-00018

	DESCRIPTION	PART NO.	QTY.
1.	RADIATOR MOUNTING BRACKET	000-04592	1
2.	MOUNTING PLATE	000-04593	1
3.	TOP BRACKET, LEFT	000-04594	1
4.	TOP BRACKET, RIGHT	000-04595	1
5.	EXTENSION TUBE	000-04614	1
6.	PLAIN WASHER ½	027-00408	2
7.	NUT M12	272-00005	2
8.	SPRING WASHER M12	272-00073	2
9.	BOLT M12 X 30	272-00118	2
10.	RADIATOR HOSE	757-10551	1
11.	HOSE CLAMP	757-13270	2

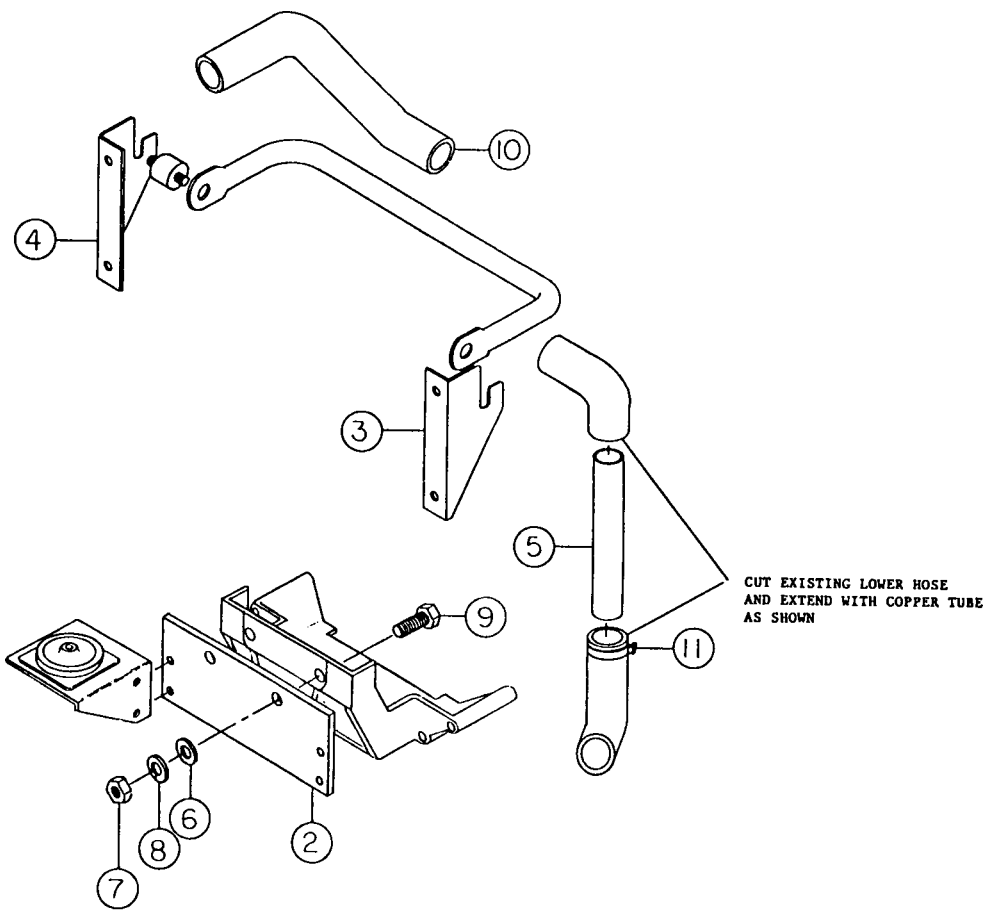

ALPHA RANGE COOLING SYSTEM — LPW/S

ALPHA RANGE COOLING SYSTEM

SUPER-LOW-PROFILE RADIATOR, LPU2 ONLY 989-00123

	DESCRIPTION	PART NO.	QTY.
1.	SPRING WASHER 3/16	000-03007	8
2.	NUT 10-32	000-03009	8
3.	PAN HEAD SCRES 10-32 X 1/2	000-03740	8
4.	RADIATOR BRACKET	000-05602	1
5.	FAN SHROUD	000-05618	1
6.	UPPER LEFT BRACKET	000-05621	1
7.	UPPER RIGHT BRACKET	000-05622	1
8.	TUBE	000-05623	1
9.	UPPER HOSE	000-05624	1
10.	HOSE BEND	000-05702	1
11.	ANTI-VIBRATION MOUNT	000-06179	2
12.	HOSE CLAMP	027-04230	2
13.	BOLT M6 X 16	272-00034	4
14.	SPRING WASHER M10	272-00072	5
15.	SOC. HD. BOLT M10 X 35	272-00206	5
16.	UPPER MOUNT	000-06339	2
17.	DISTANCE PIECE	390-01040	5
18.	FLAT WASHER M6	785011	4
19.	SPRING WASHER M6	786004	8
20.	BOLT M6 X 12	272-00032	4
	NOT SHOWN:		
	EXTRA-LARGE RADIATOR KIT	750-40671	1

THIS KIT REQUIRES THE USE OF A CRANKSHAFT-MOUNTED COOLING FAN, SHOWN ON THE FOLLOWING PAGES.

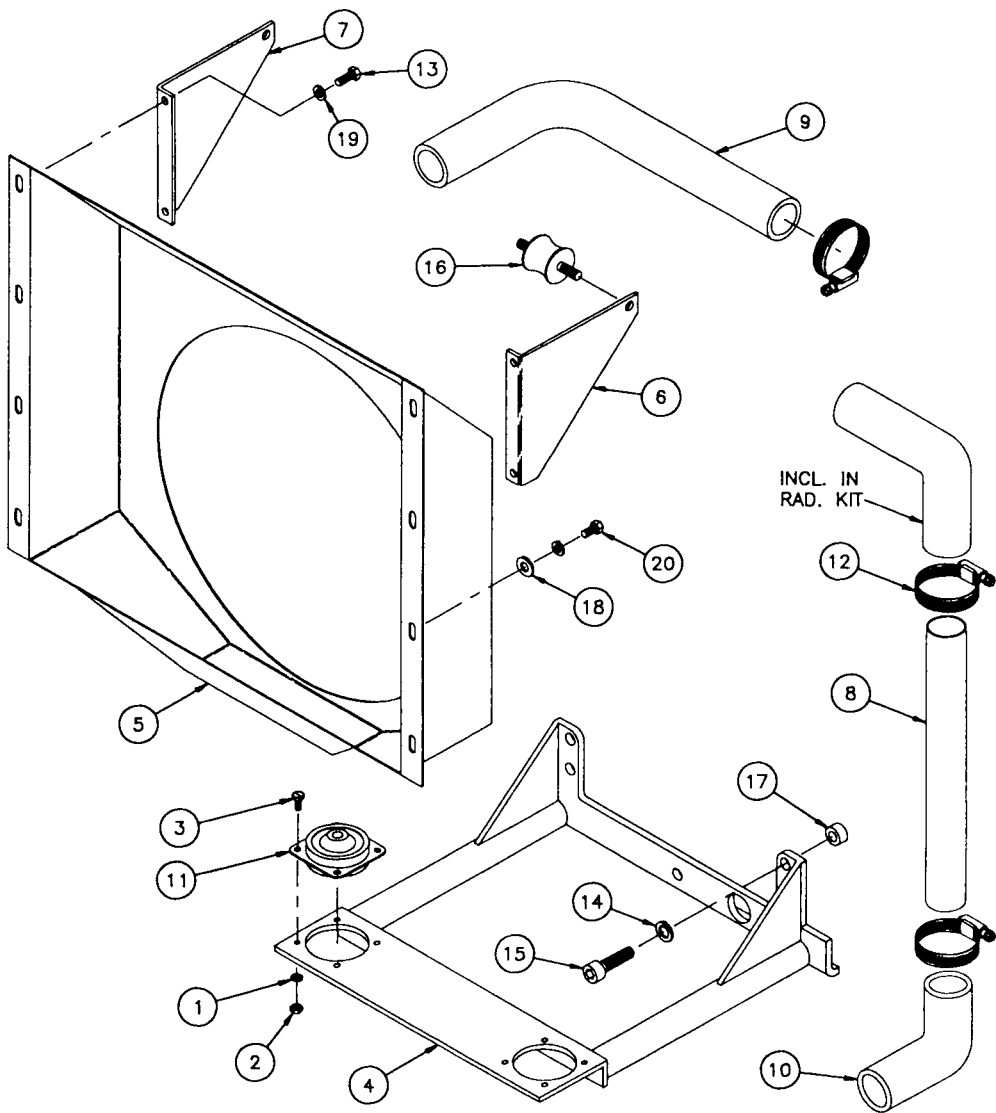

ALPHA RANGE COOLING SYSTEM — LPW/S

ALPHA RANGE COOLING SYSTEM

CRANK-MOUNTED PULLER FAN, LPW/S2 989-00148

	DESCRIPTION	PART NO.	QTY.
3.	5-VANE PULLER FAN	750-40190	1

CRANK-MOUNTED PUSHER FAN, LPW/S2 989-00149

	DESCRIPTION	PART NO.	QTY.
3.	5-VANE PUSHER FAN	750-40180	1

THE FOLLOWING COMPONENTS ARE COMMON TO ALL KITS LISTED ABOVE:

	DESCRIPTION	PART NO.	QTY.
1.	HUB	000-05523	1
2.	SOC. HD. BOLT M8 X 20	272-00243	4
5.	NUT	751-40520	1

PUSHER FAN 989-00284

	DESCRIPTION	PART NO.	QTY.
1.	PUSHER FAN	000-06873	1
2.	SPACER	000-06730	1
3.	NUT	751-40520	1

PULLER FAN 989-00285

	DESCRIPTION	PART NO.	QTY.
1.	PULLER FAN	000-06994	1
2.	SPACER	000-06730	1
3.	NUT	751-40520	1

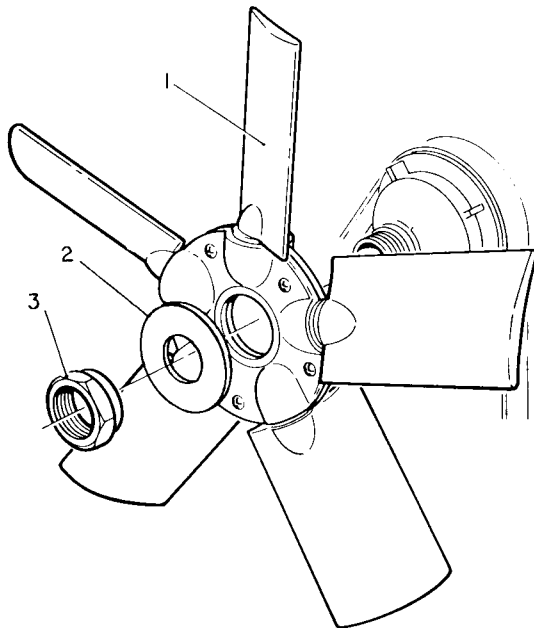
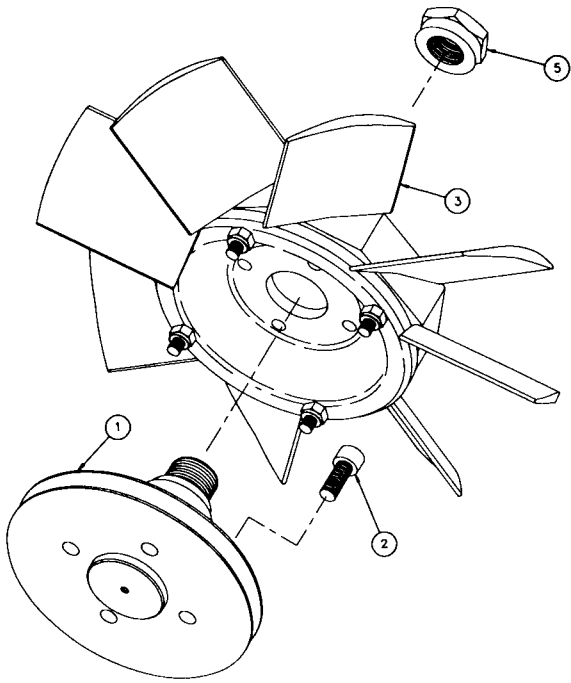

ALPHA RANGE COOLING SYSTEM — LPW/S

ALPHA RANGE COOLING SYSTEM

RADIATOR CORE GUARD, LPW/S2/3 989-00023

	DESCRIPTION	PART NO.	QTY.
1.	GUARD	000-04634	1

RADIATOR CORE GUARD, LPW/S4 989-00063

	DESCRIPTION	PART NO.	QTY.
1.	GUARD	000-04635	1

THE FOLLOWING COMPONENTS ARE COMMON TO BOTH KITS LISTED ABOVE:

	DESCRIPTION	PART NO.	QTY.
2.	BOLT M6 X 12	272-00032	8
3.	PLAIN WASHER	785631	8
4.	SPRING WASHER	786078	8

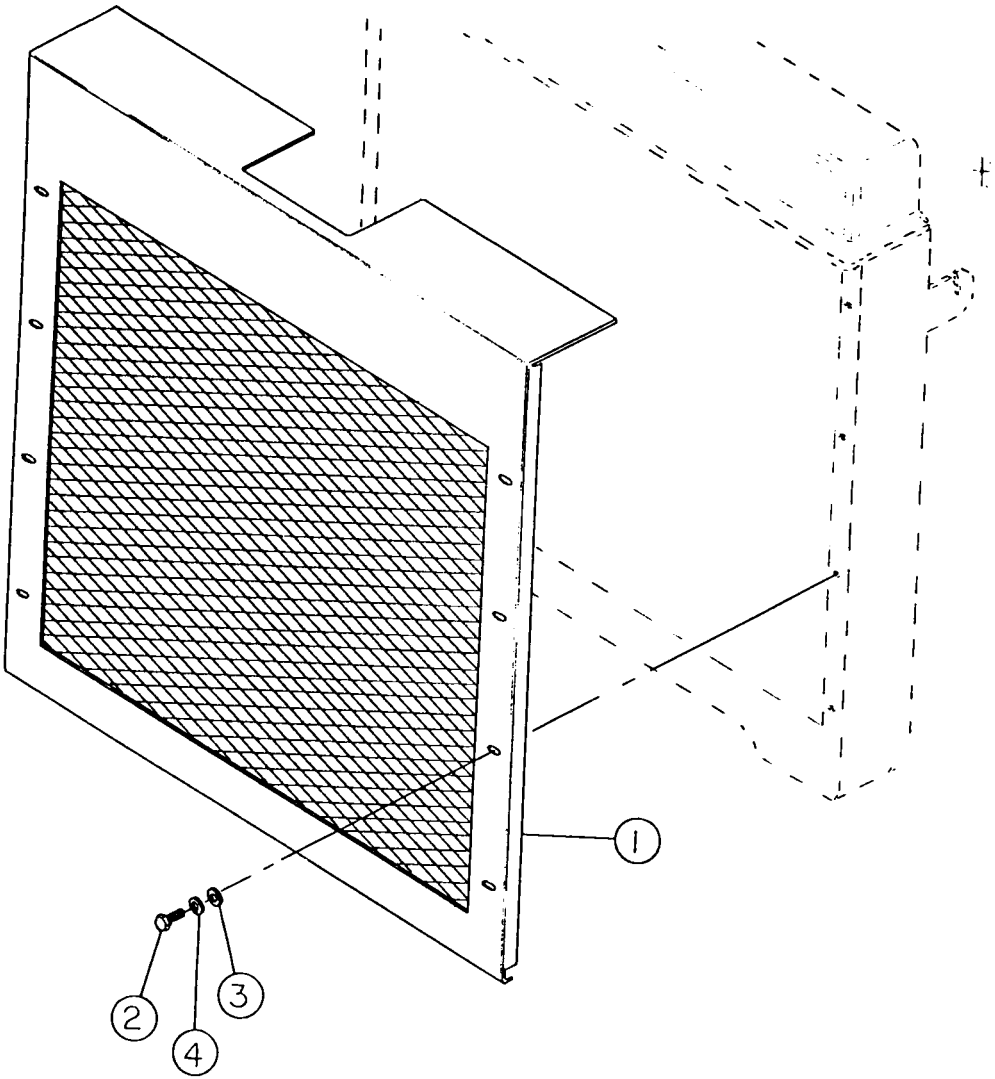

ALPHA RANGE COOLING SYSTEM — LPW/S

ALPHA RANGE STARTING & CHARGING

61 AMP DELCO ALTERNATOR 989-00175

	DESCRIPTION	PART NO.	QTY.
1.	ALTERNATOR	000-05433	1
2.	ADJUSTING LINK	000-04681	1
3.	BUSHING	000-05441	1
4.	BOLT M8 X 20	272-00039	1
5.	BOLT M8 X 100	000-05991	1
6.	PLAIN WASHER	027-00082	1
7.	SPRING WASHER M8	272-00071	3
8.	NUT M8	272-00680	1
9.	ALTERNATOR PULLEY	751-10964	1
10.	BELT	202-42200	1
11.	FLAT WASHER 5/16	064-06612/008	1
12.	FLAT WASHER M16	000-03166	1
14.	BOLT M8 X 50	272-00668	1
	NOT SHOWN:		
	PARTS FOR REGULATOR CONNECTOR		
	CONNECTOR BODY	000-06038	1
	SECONDARY LOCK	000-06039	1
	CABLE SEAL	000-06040	1
	LARGE TERMINAL	000-06041	1
	SMALL TERMINAL	000-06042	3

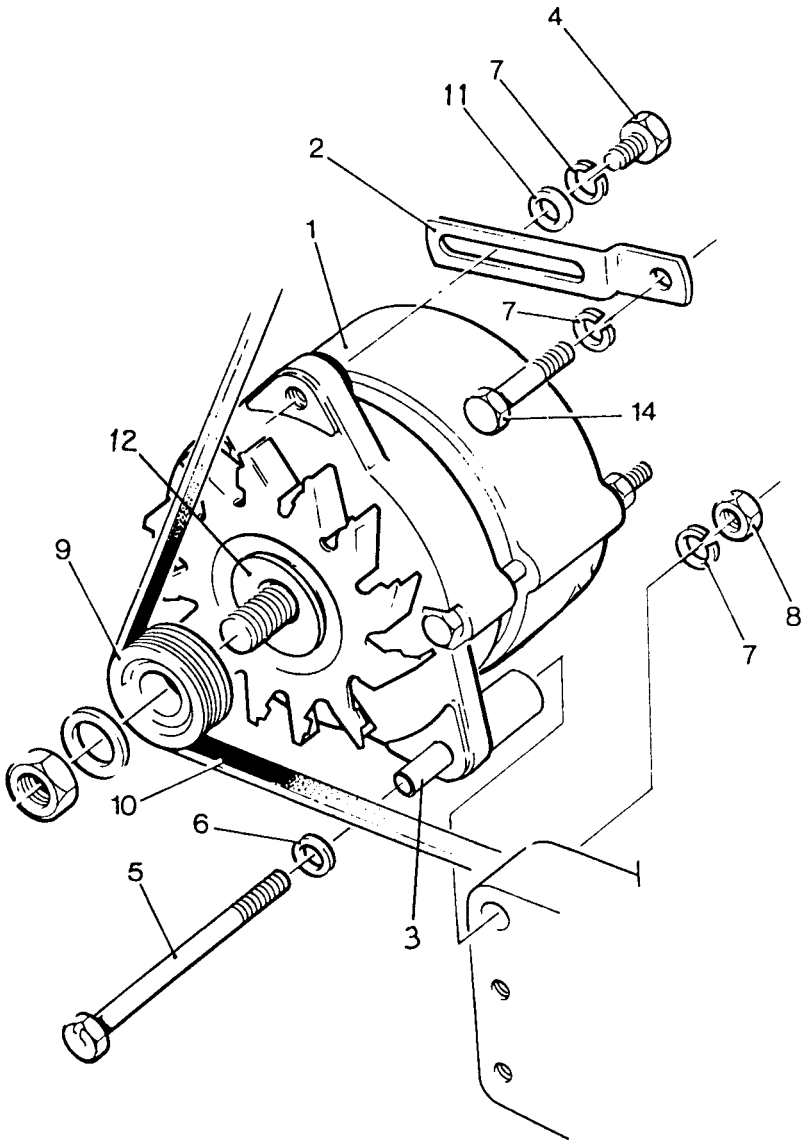

ALPHA RANGE STARTING & CHARGING — LPW/S

ALPHA RANGE STARTING AIDS

ENGINE COOLANT HEATER 989-00087

	DESCRIPTION	PART NO.	QTY.
1.	COOLANT HEATER (INCL. HOSE CLAMPS)	000-05148	1
2.	LOWER RADIATOR HOSE	000-05149	1
	NOT SHOWN:		
	OPTIONAL THERMOSTAT SWITCH, SET AT 125° F	000-05993	1

LPA ETHER START KIT 989-00279

	DESCRIPTION	PART NO.	QTY.
1.	BOLT 5/16 - 18 X 3/4	752647	5
2.	NUT 5/16 - 18	101-00602	5
3.	PLAIN WASHER 5/16	064-06612/008	4
4.	SPRING WASHER 5/16	027-00413	5
5.	COPPER WASHER	013-21778	1
6.	BOLT M6 X 55	000-06982	2
7.	MANIFOLD ADAPTOR	000-06970	1
8.	BRACKET	000-06969	1
9.	STUD M6 X 90	000-03779	1
10.	ETHER START KIT	000-01865	1

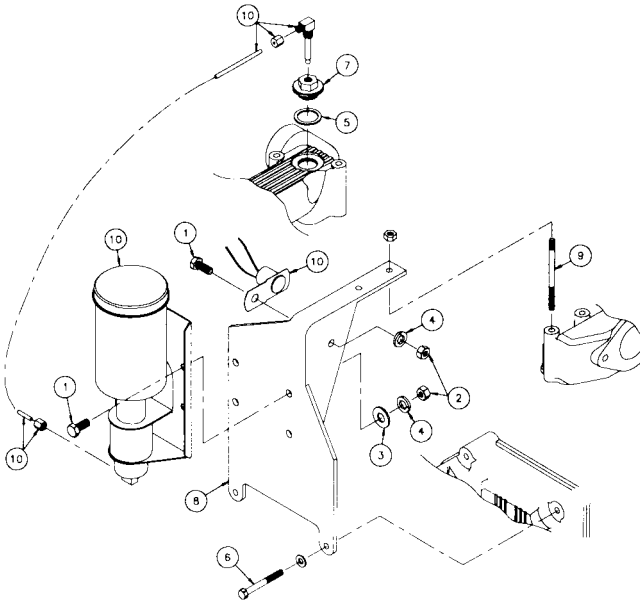
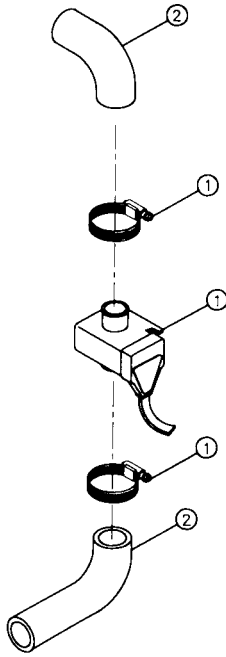

ALPHA RANGE STARTING AIDS — LPW/S

ALPHA RANGE CONTROLS

VERNIER SPEED CONTROL CABLE 989-00157

	DESCRIPTION	PART NO.	QTY.
1.	CABLE ASSEMBLY	000-01814	1
2.	SPRING WASHER 3/16	000-03007	2
3.	CABLE ANCHOR BRACKET	000-05981	1
4.	QUADRANT BRACKET	000-05982	1
5.	BRASS WASHER	101-00607	1
6.	NUT 10-32	270-00001	2
7.	SCREW 10-32 X 3/4	270-00183	2
8.	BOLT M6 X 12	272-00032	1
9.	BOLT M8 X 16	272-00038	2
10.	SPRING WASHER M8	272-00071	2
11.	SPRING WASHER M6	786004	1

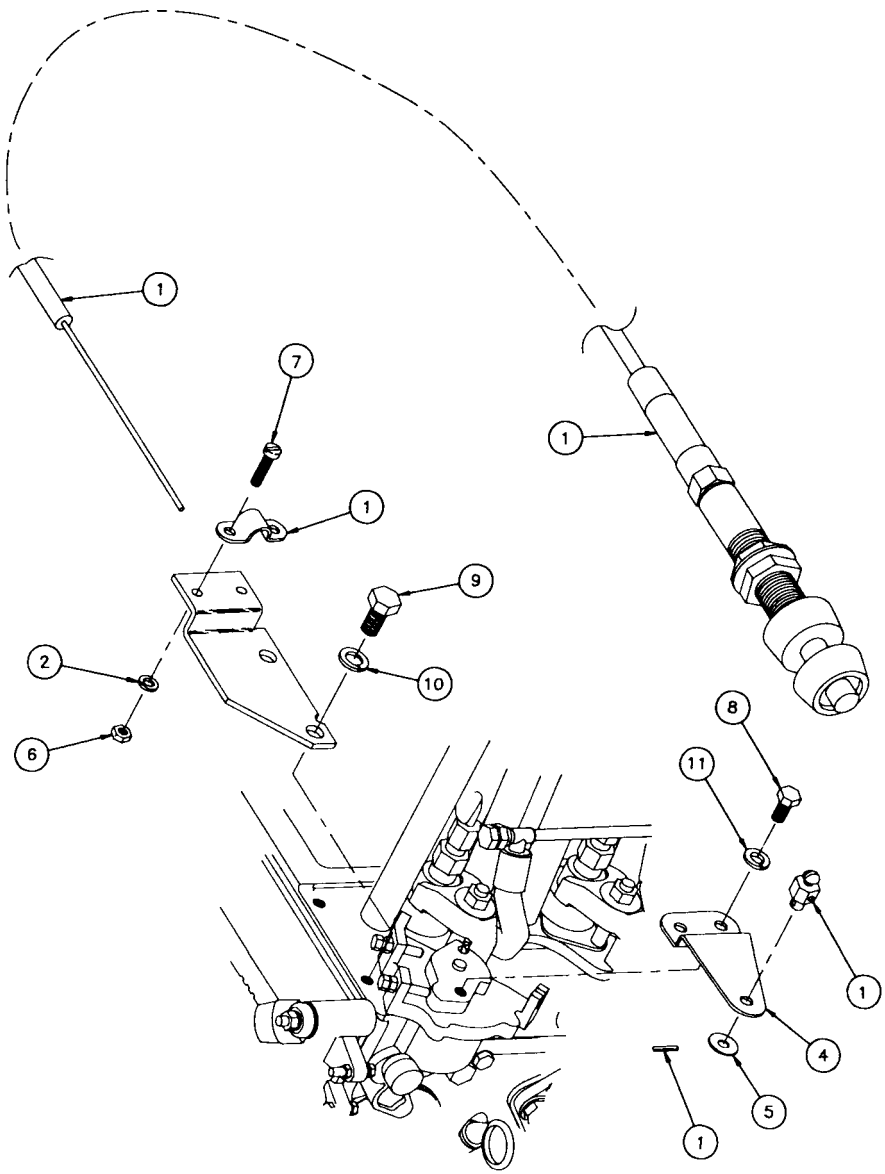

ALPHA RANGE CONTROLS — LPA, LPW/S

ALPHA RANGE INSTRUMENTS & PANELS

TEMPERATURE GAUGE & SENDER 989-00005

	DESCRIPTION	PART NO.	QTY.
1.	TEMP. GAUGE	000-02435	1
2.	TEMP. SENDER	000-04128	1
	NOT SHOWN:		
	TERMINAL, FLAG	000-01875	1
	TERMINAL , 1/4 SPADE	101-00407	3

OIL PRESSURE GAUGE & SENDER 989-00004

	DESCRIPTION	PART NO.	QTY.
3.	OIL PRESSURE GAUGE	000-02437	1
4.	OIL PRESSURE SENDER	000-02438	1
5.	45° STREET ELBOW	101-00001	1
	NOT SHOWN:		
	TERMINAL, #10	101-00402	1
	TERMINAL ,1/4 SPADE	101-00407	3

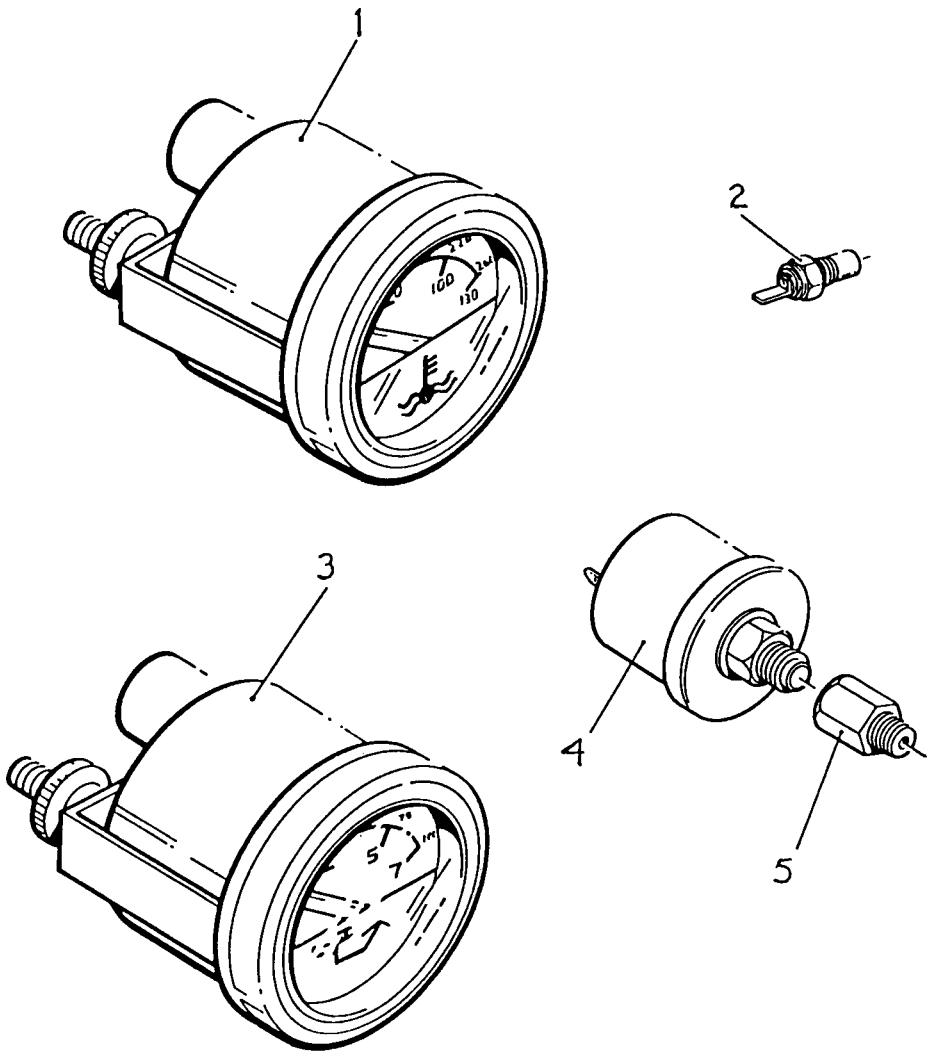

ALPHA RANGE INSTRUMENTS & PANELS — LPA, LPW/S

ALPHA RANGE INSTRUMENTS & PANELS

RATIONALISED INSTRUMENT PANEL 989-00057

	DESCRIPTION	PART NO.	QTY.
1.	INSTRUMENT PANEL	000-03345	1
2.	ROTARY SWITCH	000-02034	1
3.	LEGEND PLATE	000-03489	1
4.	OIL PRESSURE GAUGE	000-02437	1
5.	PUSH BUTTON SWITCH	000-00031	1
	SWITCH BOOT	000-01682	1
6.	TACH/HOUR METER	000-04601	1
7.	TEMPERATURE GAUGE	000-02435	1
8.	AMMETER	000-03307	1
	NOT SHOWN:		
	PANEL HARNESS	000-03597	1

USE WITH:

ENGINE FITTINGS, LPW/S3/4	989-00060
ENGINE FITTINGS, LPW/S2	989-00061
ENGINE FITTINGS, LPA3	989-00078
ENGINE FITTINGS, LPA2	989-00079

TO MOUNT PANEL REMOTE FROM ENGINE, USE EXTENSION CABLES AS FOLLOWS:

3 1/2 FT. CABLE	000-06448
10 FT. CABLE	000-03596
15 FT. CABLE	000-04477

TO MOUNT PANEL ON ENGINE, SEE KITS LISTED ON FOLLOWING PAGE.

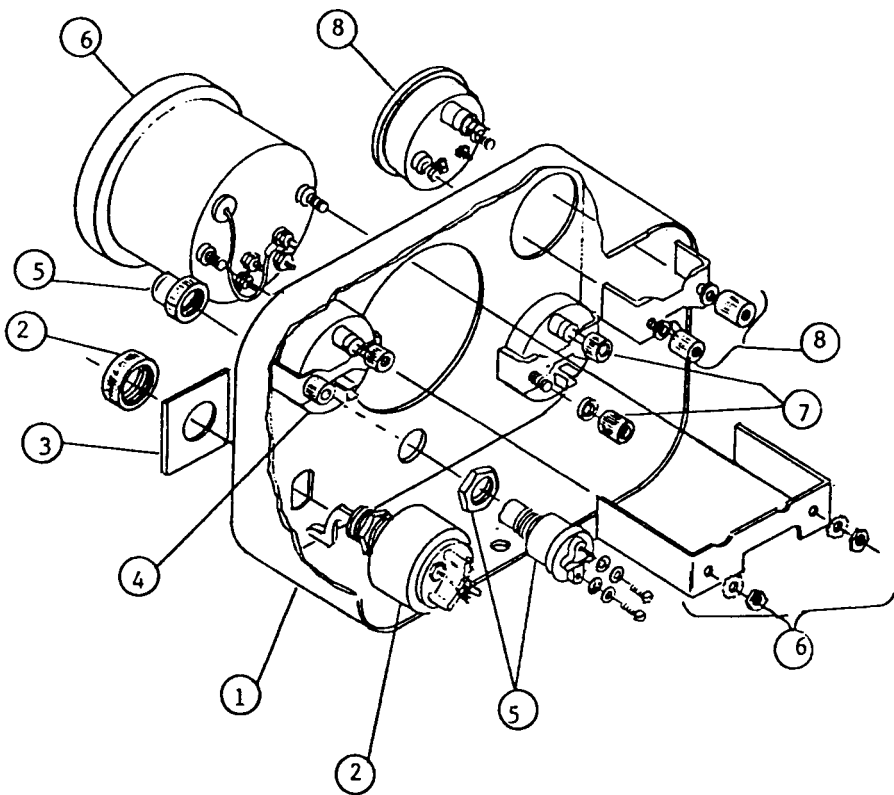

ALPHA RANGE INSTRUMENTS & PANELS — LPA, LPW/S

ALPHA RANGE INSTRUMENTS & PANELS

LOW PANEL MOUNT, LPW/S3/4, LPA3 989-00058

	DESCRIPTION	PART NO.	QTY.
1.	ANTI-VIBRATION MOUNT	000-02682	3
2.	PLAIN WASHER	000-03008	2
3.	SPRING WASHER M10	272-00072	4
4.	SPRING WASHER 1/4	786078	6
5.	NUT 1/4 UNC	756606	6
6.	BOLT M10 X 25	272-00067	4
7.	BRACKET	000-04604	1

HIGH PANEL MOUNT, LPW/S2/3/4, LPA2/3 989-00059

	DESCRIPTION	PART NO.	QTY.
1.	ANTI-VIBRATION MOUNT	000-02682	3
2.	PLAIN WASHER	000-03008	2
4.	SPRING WASHER 1/4	786078	6
5.	NUT 1/4 UNC	756606	6
8.	SPRING WASHER M8	272-00071	4
9.	BOLT M8 X 20	272-00243	4
10.	BRACKET	000-04618	1

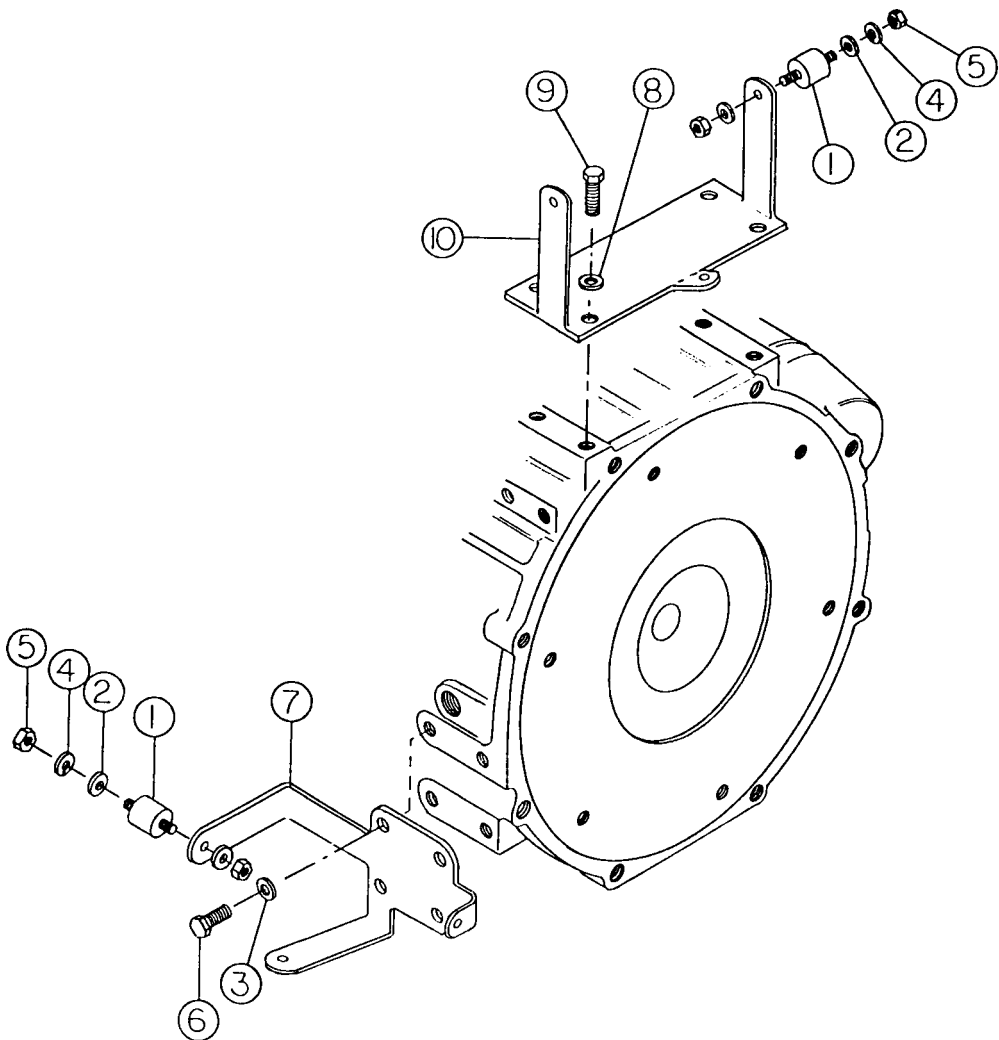

ALPHA RANGE INSTRUMENTS & PANELS — LPA, LPW/S

ALPHA RANGE INSTRUMENTS & PANELS

LPW/S START PANEL W/2 LAMPS, ENGINE MOUNTED 989-00138

	DESCRIPTION	PART NO.	QTY.
1.	PANEL	000-05754	1
2.	KEY SWITCH	602-53000	1
3.	UPPER BRACKET	000-05755	1
4.	LOWER BRACKET	000-05756	1
5.	HI TEMP. LAMP	750-40350	1
6.	LOW OIL PRESS. LAMP	750-11120	1
7.	ANTI-VIBRATION MOUNT	000-02682	3
8.	RELAY	000-04472	1
9.	SCREW 10-32 X 1/2	000-03740	1
10.	NUT 10-32	000-03009	1
11.	NUT 1/4-20	756606	6
12.	SPRING WASHER 1/4	786078	6
13.	BOLT M10 X 20	272-00241	3
14.	SPRING WASHER M10	272-00072	3
15.	SPRING WASHER 3/16	000-03007	1
16.	FLAT WASHER 1/4	000-03008	2
17.	OIL PRESSURE SWITCH	750-11110	1
18.	HI TEMP. SWITCH	750-10281	1
	NOT SHOWN:		
	WIRING HARNESS	000-05752	1

LPW/S START PANEL W/2 LAMPS, REMOTE MOUNT 989-00139

	DESCRIPTION	PART NO.	QTY.
.	PANEL	000-05754	1
2.	KEY SWITCH	602-53000	1
5.	HI TEMP. LAMP	750-40350	1
6.	LOW OIL PRESS. LAMP	750-11120	1
8.	RELAY	000-04472	2
9.	SCREW 10-32 X 1/2	000-03740	1
10.	NUT 10-32	000-03009	1
15.	SPRING WASHER 3/16	000-03007	1
17.	OIL PRESSURE SWITCH	750-11110	1
18.	HI TEMP. SWITCH	750-10281	1
	NOT SHOWN:		
	WIRING HARNESS	000-05706	1
	RELAY HARNESS	000-06189	1

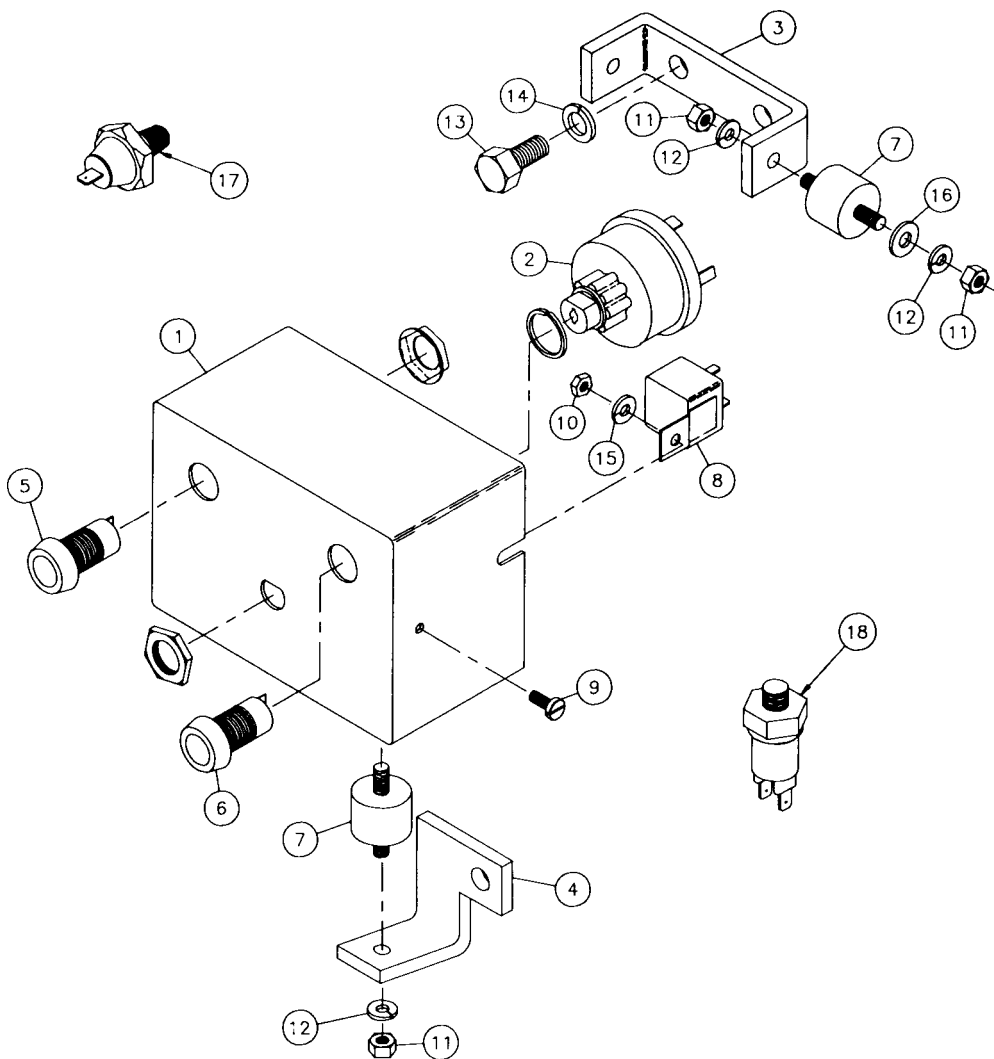

ALPHA RANGE INSTRUMENTS & PANELS — LPW/S

ALPHA RANGE PROTECTION DEVICES

HIGH WATER TEMPERATURE SWITCH

DESCRIPTION	PART NO.	QTY.
1. TEMPERATURE SWITCH	000-06175	1

LOW OIL PRESSURE SWITCH

DESCRIPTION	PART NO.	QTY.
1. OIL PRESSURE SWITCH	000-05659	1

2-WIRE ETR SOLENOID 3,4-CYL. 989-00297

DESCRIPTION	PART NO.	QTY.
1. BOLT M6 X 65	000-04712	1
2. STOP LEVER	000-07073	1
3. ROD	000-07074	1
4. DISTANCE PIECE	000-07075	2
5. DISTANCE PIECE	000-07076	1
6. SOLENOID BRACKET	000-07077	1
7. BOLT M6 X 40	272-00036	2
8. M6 NUT	272-00679	3
9. BOLT M5 X 10	272-00690	2
10. BOLT M6 X 14	272-00693	2
11. SPRING WASHER	786303	3
12. WASHER	785352	2
13. SPRING WASHER	786078	3
14. SOLENOID	366-07197	1
NOT SHOWN: OIL PRESSURE ADAPTOR	757-17650	1

3-WIRE ETR SOLENOID 3,4-CYL. 989-00290

DESCRIPTION	PART NO.	QTY.
AS ABOVE, EXCEPT: 14. SOLENOID	000-03720	1

24-VOLT ETR SOLENOID 3,4-CYL. 989-00302

DESCRIPTION	PART NO.	QTY.
AS ABOVE, EXCEPT: 14. SOLENOID	000-06825	1

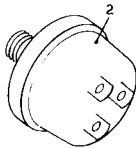
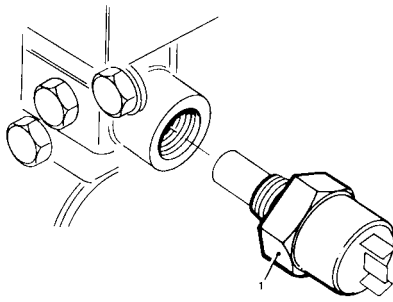

ALPHA RANGE PROTECTION DEVICES — LPW/S

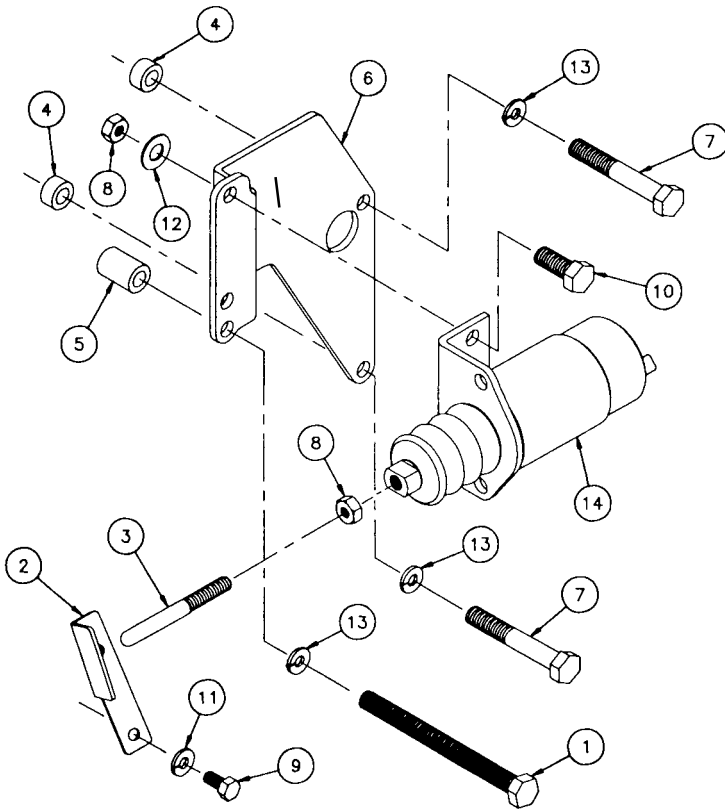

ALPHA RANGE PROTECTION DEVICES — LPA, LPW/S

